



**Resource Data Collection, Analysis & Control (RDC)  
For  
IP-Based Services  
Service Specification –  
IP Television (IPTV)**

**Version 3.5-A.0.0  
Industry Review Draft**

**July 26, 2006**

**© 1999-2006 IPDR.org, Inc.**

## Preface

### Contacts

For general questions regarding this document and referrals to technical experts for detailed questions, please contact:

Chief Editor: Steve Cotton  
Cotton Management Consulting  
[editor@ipdr.org](mailto:editor@ipdr.org)

#### **Business Requirements Working Group** –

Lead: Betty Cockrell  
BSG Clearing Solutions  
[Betty.Cockrell@bsgclearing.com](mailto:Betty.Cockrell@bsgclearing.com)

Editor: Pat Walls  
Syniverse Technologies, Inc.  
[Patricia.Walls@syniverse.com](mailto:Patricia.Walls@syniverse.com)

#### **Protocol Working Group** –

Lead: Tal Givoly  
Amdocs

Editor: Amit Kleinmann  
Amdocs

### Acknowledgments

The following member companies contributed materially to the creation of this release of the document:

#### **Charter Members**

Amdocs  
BSG Clearing Solutions  
Syniverse Technologies

#### **Supporting Members**

#### **Associate**

**Member/Liasion Orgs**  
ATIS/OBF IP-NNI  
Committee

### Abstract

This document is a companion to NDM-U, which specifies the overall business requirements and protocol generic to all services. The content herein is compliant to those requirements and specifications and is particular to the service specified.

### Change History

<b><u>Revision</u></b>	<b><u>Date</u></b>	<b><u>Author</u></b>	<b><u>Remarks</u></b>
Initial Draft	March 27, 06	Amit Kleinmann & Steve Cotton	
R. Draft 1	April 3, 06	Amit Kleinmann	
R. Draft 2	April 10, 06	Amit Kleinmann	
R. Draft 3	April 17, 06	Amit Kleinmann & Steve Cotton	
R. Draft 4	May 21, 06	Amit Kleinmann & Steve Cotton	

Service Specification – IPTV.....3.5-A.0.0 Industry Review Draft

R. Draft 5	May 25, 06	Amit Kleinmann & Greg Weber	IPv4 address was changes to general IP address (either v4 or v6)
R. Draft 6	May 31, 06	Amit Kleinmann & Steve Cotton	Added elements to reflect new use cases, aligned schema definition
R. Draft 7	July 10, 06	Steve Cotton	Added elements to reflect more IIF use cases
Industry Review Draft	July 26, 06	Steve Cotton	At direction of BRWG

**Table of Contents**

**1 Introduction.....5**

1.1 Purpose.....5

1.2 Scope.....5

1.3 Compatibility .....5

1.4 References.....5

1.5 Overview.....6

**2 IPTV Specification.....7**

2.1 IPTV Network Architecture.....7

2.2 IPTV Services .....10

2.2.1 Main IPTV services .....10

2.2.2 Supplementary Features of IPTV Services .....12

2.3 Use Cases .....13

2.3.1 Basic Flow – View a Program on a Pre-Subscribed Channel.....13

2.3.2 Basic Flow – View PPV Program.....14

2.3.3 Basic Flow – View VOD Program .....15

2.3.4 Advanced Flow – View a Program With Pause and Resume .....15

2.3.5 Advanced Flow - Multi-Room Viewing .....16

2.3.6 Advanced Flow – Selection of Subtitles and Audio Track.....17

2.3.7 Receive Caller ID on Screen.....17

2.3.8 Alternate Flow – Advertisement Offer .....18

**3 IPTV Accounting Requirements .....19**

3.1 High Level Requirements of an IPTV Accounting.....19

3.2 IPTV Entities Handling Accounting & Usage Collection .....20

3.3 Usage Attribute List.....21

3.3.1 General IPDR Attributes.....21

3.3.2 IPTV Usage Data Exporter Information .....22

3.3.3 IPTV Receiving Device Information .....22

3.3.4 IPTV Consumer/Viewer Information .....23

3.3.5 IPTV Record Information .....23

3.3.6 IPTV Service Consumption Information .....24

3.3.7 IPTV Quality of Experience (QoE) Information .....25

**Table 1 - Service Usage Element Names .....26**

**4 Formal Specification.....28**

4.1 Schema.....28

4.2 Sample Instance Document.....35

## 1 INTRODUCTION

---

### 1.1 PURPOSE

This document is intended to specify the business use case and formal XML Schema for an IP-based television service.

### 1.2 SCOPE

This document is limited to the discussion of issues as defined by the mission statement of IPDR.org, namely:

The IPDR Organization (the “Organization”) is organized and operates as a non-stock not for profit organization for the following purposes:

- (a) To develop, agree upon and publish a non-proprietary, open specification for the representation and encapsulation of Internet Protocol (IP)-based events for use by business, operations and decision support systems. Such events include, but are not limited to, IP-based network services, application services and e-commerce transactions;
- (b) To develop, agree upon and publish a non-proprietary, open specification for the representation and encapsulation of IP-based network and service elements provisioning events;
- (c) To promote work accomplished and uniform specifications to the industry and submit approved published specifications to the appropriate standards bodies for acceptance in the public domain; and
- (d) To have and exercise all powers necessary or convenient to affect any or all of the purposes for which the Organization is organized.

### 1.3 COMPATIBILITY

Future revisions are expected to make every attempt to preserve investments made by service providers and solution vendors by considering backward and forward compatibility whenever it is practical.

### 1.4 REFERENCES

- [1] NDM-U 3.0, IPDR.org.
- [2] XML Schema Part 1: Structures, W3C Working Draft 7 April 2000.
- [3] XML Schema Part 2: Data Types, W3C Working Draft 7 April 2000

## 1.5 OVERVIEW

This specification is divided into two major chapters:

- Service Specification – description of the specific requirements and business use case for the service in question.
- Formal Specification – XML Schema description of the IPDR Record for this service.

## 2 IPTV SPECIFICATION

### 2.1 IPTV NETWORK ARCHITECTURE

#### High Level IPTV Network Architecture

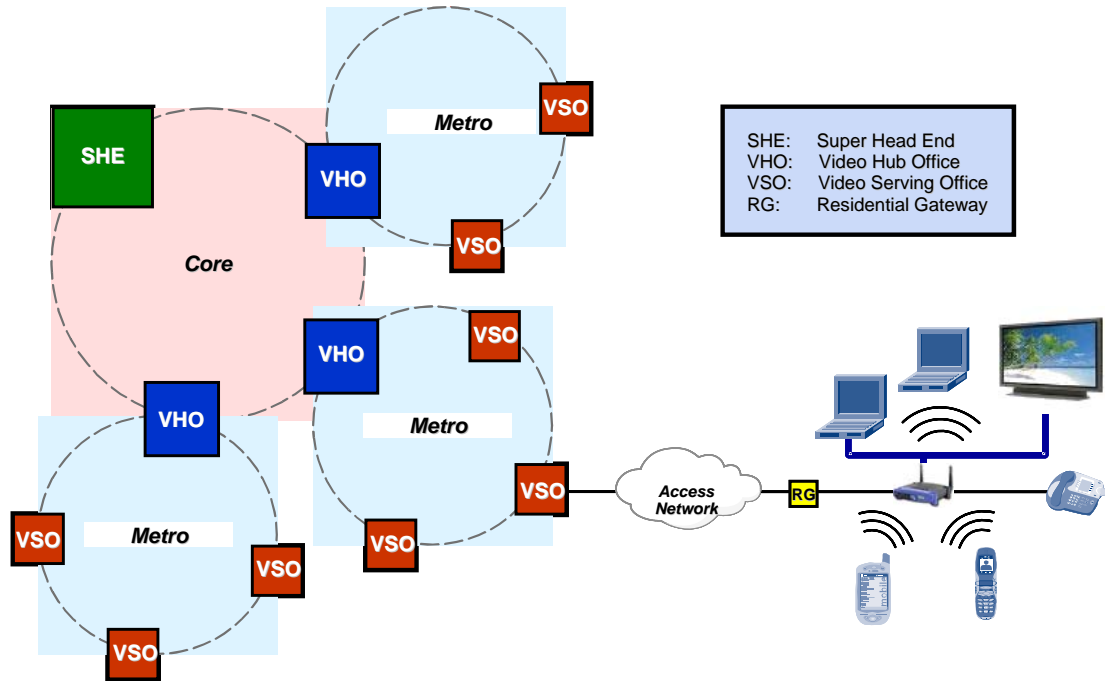

Super Head End (SHE) - the locations for acquisition and aggregation of national-level broadcast TV (or linear) programming. SHEs are also the central point of on-demand content insertion.

Video Hub Office (VHO) - the video distribution points within a demographic market area (DMA) National content is received from each SHE. Local content is acquired and encoded. VOD servers and other application servers typically located in the VHOs. Insertion of local advertising is also performed in the VHO. IPTV services are provided from the VHO via the aggregation/access network.

Video Serving Office (VSO) - contains/hosts all access systems used to connect the CO's (a VSO assumed to be a Central Office) to the subscribers. In addition, the VSO contains aggregation equipment to enable efficient and reliable interconnection to the VHO.

Residential Gateway (RG) - Network node dedicated to a single subscriber / household providing traffic management and routing between the access network and the home network. The RG function may be integrated with the network termination. The RG is a trusted device and is managed from the network.

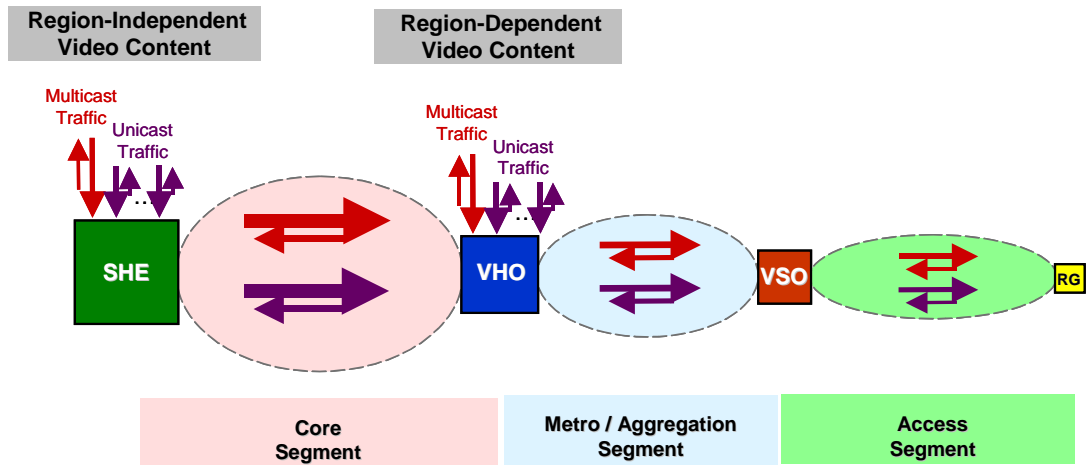

Core Network Segment - A Service Provider’s IPTV Core Network interconnects a small number of SHE’s - potentially national in scope and application -- to a larger number of VHOs -- typically regional in scope and application. Current core IP backbone networks are likely to be leveraged since they are already in place to many candidate VHOs and should be able to readily handle the incremental bandwidth that is expected to be required.

Metro / Aggregation Segment

Access Segment

Home Network – The Network Interface Device (NID) is considered the demarcation point between the WAN and the home network in copper-to-the-premises deployments, while the Optical Network Terminal (ONT) is considered the demarcation point between the WAN and the home network in fiber-to-the-premises deployments

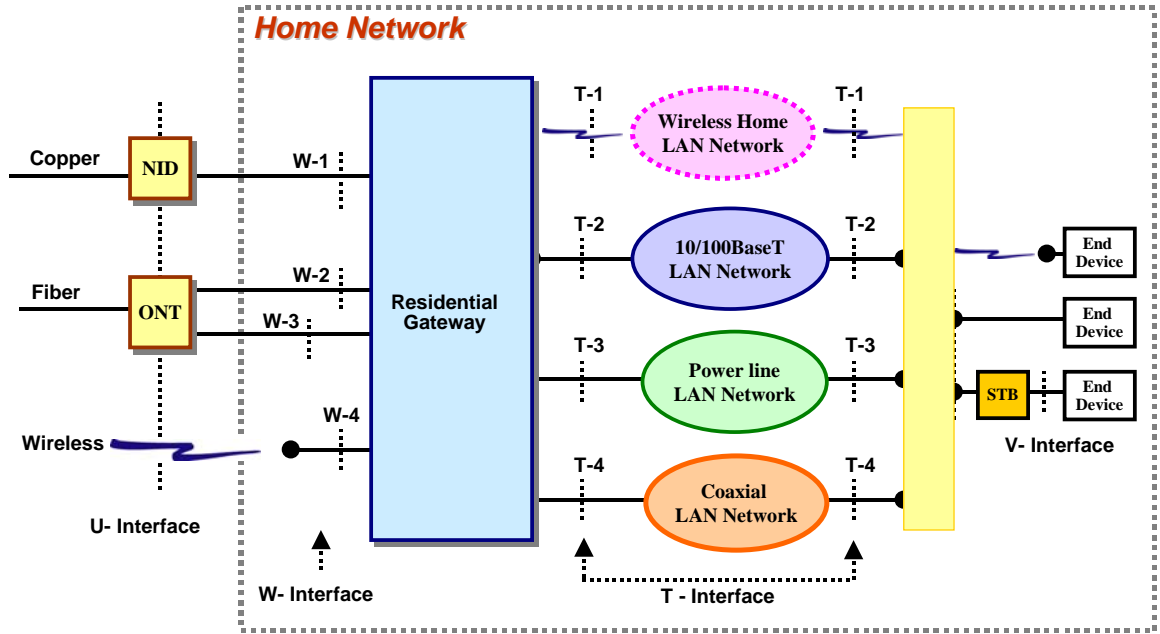

## 2.2 IPTV SERVICES

The IPTV services are hereby classified into Main IPTV services and supplementary features of IPTV services. A main IPTV service is any service that is the main cause for why a user is viewing/interacting-with the TV at a given moment. In contrast a supplementary feature of an IPTV service is a feature that even when it is consumed by the user, it is not the main reason why the user views/interacts with the TV.

### 2.2.1 MAIN IPTV SERVICES

Following is a list of main IPTV services:

1. **IPTV Linear/Broadcast TV** - the classic form of SDTV/HDTV offered by cable, terrestrial broadcasters and direct broadcast satellite providers. It provides an essentially continuous stream flowing from the content provider to the IPTV RECEIVING DEVICE. In the IPTV context this continuous stream is most commonly delivered via a one to many or multicast network. The following are various flavors of IPTV Linear TV with supplementary services:
  - 1.1. Subtitles and captions
  - 1.2. Multilanguage audio tracks
  - 1.3. PPV (Pay Per View) - an offering of pay-television broadcasts to customers in a manner that they can buy a particular program event separately from any package or subscription. The program event is shown at the same time to everyone ordering it.
    - PPV Purchase can be done via:
      - a phone call to contact an automatic response unit (ARU) utilizing automatic number identification (ANI)
      - a phone call to customer service representative (CSR)
      - filling and sending a form in an Internet web site
      - filling and sending a form on an interactive TV e.g., on an electronic program guide, using the remote control.
    - PPV prices can be changed to meet demand or to encourage subscribers to order early.
    - PPV purchase time – PPV ordering can be done prior the program and in certain occasion after the program was already started, e.g., it is possible to order the program several days in advance, alternatively, in some cases it is made possible to watch the first few minutes of an event before ordering.
    - PPV report back - event purchases may be stored in the set-top box (or the proper server) until an event based (or time based) request for data is received and the data is accurately retrieved.

- 1.4. Digital Video Recording (DVR)
- 1.5. Linear broadcast with Trick mode functionality
- 1.6. Multi-room viewing – e.g., ability to stop viewing on TV in one room and resume viewing on TV in another room.
- 1.7. Linear broadcast with iTV
- 1.8. Linear broadcast with communication/messaging
- 1.9. Customer originated Video
2. **IPTV Video on Demand (VOD)** - The Video on Demand service enables TV viewers to select TV videos from a central repository for viewing on a television at their desired time. VOD systems are either “streaming VOD” or “push VOD”:
  - Streaming VOD is VOD in which rendering on the display device/viewing can (simultaneously) start as (or at least overlaps with) the video distribution over the network
  - Push VOD is VOD in which the program is brought in its entirety to a set-top box before viewing starts (it can either be invoked by the viewer or by the operator without an explicit viewer request).

There maybe multiple independent unicast viewing sessions for a given piece of content.

There are a few variations of VoD which usually have to do with the method via which the VoD service is billed/charged to the consumer. These include Subscription VoD (SVoD), Free VoD (FVoD) etc.

The following are various flavors of VOD with supplementary services:

  - 2.1. VOD with Subtitles and captions
  - 2.2. VOD with Multilanguage audio tracks
  - 2.3. VOD with Trick mode functionality.
  - 2.4. Multi-room viewing VOD
  - 2.5. VOD with iTV
  - 2.6. VOD with communication/messaging
  - 2.7. Customer originated VOD
3. **IPTV Audio services**
  - 3.1. Dedicated radio/music channels (per genre of music)

3.2. Audio/Music on Demand (MoD) – either streaming or pushed/download to play

4. **IPTV gaming**
5. **IPTV Picture management**
6. **IPTV directory service** (local yellow pages)

## **2.2.2 SUPPLEMENTARY FEATURES OF IPTV SERVICES**

Following is a list of supplementary features of IPTV services:

1. Subtitles and captions - captions on video are text located somewhere on the picture (covering a portion of the picture).
  - CLOSED captions versus OPEN captions – CLOSED captions are captions that are hidden in the video signal, invisible without a special decoder. OPEN captions are captions that have been decoded, so they have become an integral part of the television picture and thus cannot be turned off.
  - Translation of the dialog only versus translation of the full audio - Subtitles and captions are terms that are sometimes used as synonyms. However there are cases where the term subtitle is used in the context of hearing audiences while captions in the context of deaf audiences, e.g., subtitles may translate the dialog into a different language, but rarely show all of the audio (for example, captions show sound effects (e.g., "phone ringing" and "footsteps"), while subtitles don't).
  - International and Multilingual Captioning - Certain IPTV programs support International and Multilingual Captioning and allow selection of the desired language out of a list of supported languages.
  - Online versus offline captioning – Online captions can be done from a script, or actually created in real-time (usually by human transcriber but there are also trials of using new speech recognition technologies to automatically convert speech into written text). Offline captioning is done "after the fact," in a studio. Examples of offline captioning include television game shows, videotapes of movies, and corporate videotapes (e.g., training videos). The text of the captions is created on a computer, and synchronized to the video using time-codes. They are then transferred to the videotape before it is broadcast or distributed
2. Multilanguage audio tracks
3. Trick mode functionality - a subset of VCR functionality such as: pause, play, rewind, fast forward, slow forward, slow rewind, jump to previous/future frame of the video, etc.

4. Interactive TV (iTV) - allow viewers to interact with TV meta-content or to interact with the TV content itself, as they view:
  - Interaction with TV meta-content - getting more information about what is on the TV, whether sports, movies, news, or the like. Self ordering, e.g., pay the bills, getting more information about what is being advertised, along with the ability to buy it (TV-commerce).
  - Interaction with TV content - The program, itself, might change based on viewer input. Advanced forms, which still have uncertain prospect for becoming main stream, include dramas where viewers get to choose plot details and endings. Simpler forms, which are enjoying some success, include programs that directly incorporate polls, questions, comments, and other forms of (virtual) audience response back into the show.
5. Customer originated video/audio – TV viewers are able to upload content they create, and make it available to any other viewer for viewing/listening, live or offline
6. Communication/Messaging – facilitation of convergence of classical Television services with telephony and internet based communication services
7. Interactive Program Guide (IPG) - IPG is a service facilitated by the middleware, which provides the viewers detailed information about the content available to them. A viewer interacts with the network through the IPTV Receiving Device to receive the information. This viewer interaction may trigger control transactions with the network.

PiP (Picture in picture) – allows watching more than one TV program (channel) at the same time on the TV. One program is displayed on the entire TV screen, and another program or programs are displayed in individual smaller squares on the screen. For example PiP can be used for the purpose of watching a recording while using the secondary frame to show the viewer that desired broadcast programming is on, or vice versa.

## 2.3 USE CASES

### 2.3.1 BASIC FLOW – VIEW A PROGRAM ON A PRE-SUBSCRIBED CHANNEL

- **DESCRIPTION**  
A viewer selects a Pre-Subscribed Channel and watch a program that is broadcasted on this channel.
- **ACTORS**  
Viewer  
IPTV set-top box (or IPTV multicast server)
- **STEPS**
  1. Viewer – selects a pre-subscribed channel.

2. IPTV set-top box (or IPTV multicast server) - tunes to the specified channel.
3. Viewer – views a program that is multicasted on the pre-subscribed channel.

### 2.3.2 BASIC FLOW – VIEW PPV PROGRAM

- **DESCRIPTION**

A viewer selects a PPV program, pays for it either in advance, instantly, or (if allowed) few minutes after the program has already started.

- **ACTORS**

Viewer  
IPTV set-top box (or IPTV multicast server)

- **STEPS**

1. Alternative 1 – Order Ahead PPV:
  - a. Viewer – selects a PPV program and orders it (commits to pay a certain price for viewing it) in advance.
  - b. Viewer – at the proper date and time, selects the PPV program s/he already ordered.
  - c. IPTV set-top box (or IPTV multicast server) - tunes to the specified channel.
  - d. Viewer – views a program that is multicasted on the PPV channel.
2. Alternative 2 – Instantly Order PPV:
  - a. Viewer – at the proper date and time selects a PPV program and orders it (commits to pay a certain price for viewing it).
  - b. IPTV set-top box (or IPTV multicast server) - tunes to the specified channel.
  - c. Viewer – views a program that is multicasted on the PPV channel.
3. Alternative 3 – Post Order PPV
  - a. Viewer – at the proper date and time selects a PPV program without ordering it (if allowed).
  - b. IPTV set-top box (or IPTV multicast server) - tunes to the specified channel.
  - c. Viewer – views a program that is multicasted on the PPV channel for the allowed period of time (usually first few minutes).
  - d. Viewer decides whether s/he would like to continue viewing the program. Only in case the viewer wants to continue viewing the program, the viewer order the program (commits to pay a certain price for viewing it).
  - e. IPTV multicast server – In case the viewer does not express an interest to continue viewing the program, stops the multicasting/playing of the media content for the specific viewer.

### 2.3.3 BASIC FLOW – VIEW VOD PROGRAM

- **DESCRIPTION**  
A viewer selects a VOD program, order it (commit to pay a certain price) and view it once, or view it any time within a certain time limit (e.g., 24 hours)..
- **ACTORS**
  - Viewer
  - IPTV VOD server
- **STEPS**
  - Viewer – selects a VOD program and orders it (commits to pay a certain price for viewing it).
  - IPTV VOD server – deliver the VOD program to the viewer’s set-top box.
  - Viewer – views the VOD program.

### 2.3.4 ADVANCED FLOW – VIEW A PROGRAM WITH PAUSE AND RESUME

- **DESCRIPTION**  
A viewer view media content of choice that is either:
  - broadcasted on a Pre-Subscribed Channel,
  - broadcasted in a PPV manner, or
  - delivered on demand in a VOD fashion

The viewer, then, may pause and resume the media content. After pausing and resuming the media content, the viewer may skip (backward and forward) portions of the media content.
- **ACTORS**
  - Viewer
  - IPTV set-top box (or IPTV multicast/VOD server)
  - IPTV PVR
- **STEPS**
  1. Viewer – selects a program from a pre-subscribed channel, PPV schedule, or VOD program list.
  2. IPTV set-top box (or IPTV multicast/VOD server) - tunes to the specified channel and deliver the media content.
  3. Viewer – views media content of choice
  4. Viewer – may press the pause key on the remote control to pause the media content  
IPTV PVR – start recording the media content
  5. Viewer – may press the resume key on the remote control to continue the playing of the media content  
IPTV PVR – stop recording the media content

6. Viewer – may press the fast/slow forward button or the fast/slow backward button on the remote control to skip to a specific location at the stored media content (in case there is recorded media content at the PVR).

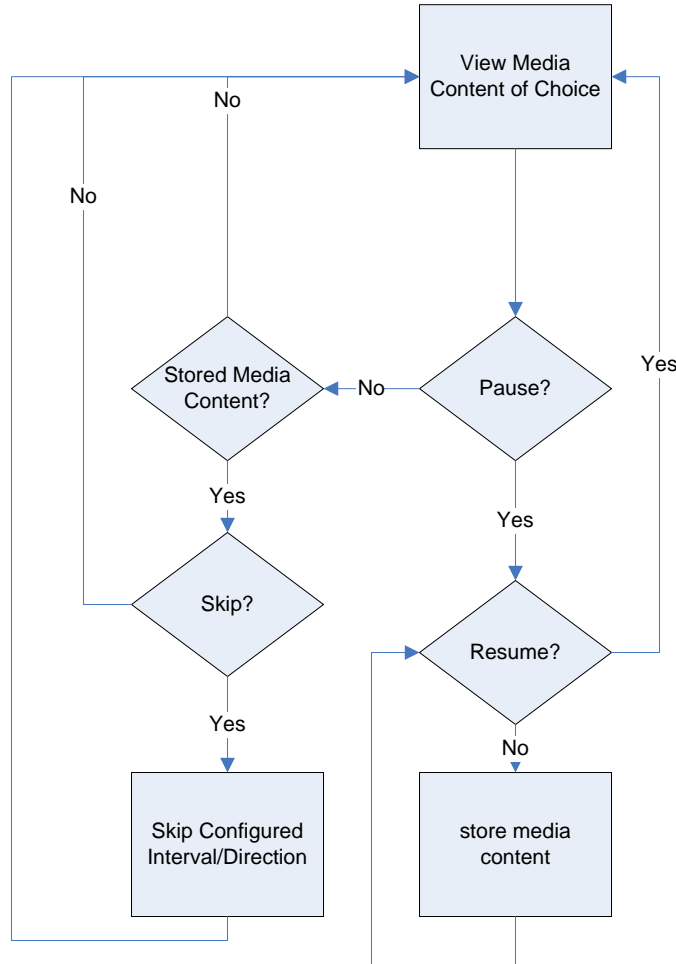

### 2.3.5 ADVANCED FLOW - MULTI-ROOM VIEWING

- **DESCRIPTION**

A viewer view media content of choice that is either:  
 broadcasted on a Pre-Subscribed Channel,  
 broadcasted in a PPV manner, or  
 delivered on demand in a VOD fashion

The viewer, then, may pause the playing of the media content at a set-top box located in a certain room and resume the media content at a different set-top box located in a different room. After pausing and resuming the media content, the viewer may skip (backward and forward) portions of the media content.

- **ACTORS**
  - Viewer
  - IPTV set-top box (or IPTV multicast/VOD server)
  - IPTV PVR
- **STEPS**
  - See previous section 2.3.4)

### 2.3.6 ADVANCED FLOW – SELECTION OF SUBTITLES AND AUDIO TRACK

- **DESCRIPTION**

A viewer selects subtitle language and/or language of audio track for a program s/he watches or is about to watch. The program may be delivered over a Pre-Subscribed Channel or via VOD.
- **ACTORS**
  - Viewer
  - IPTV set-top box (or IPTV multicast server)
- **STEPS**
  1. Viewer – selects a program to watch (from a pre-subscribed channel, PPV or VOD schedule)
  2. Viewer – may selects subtitle language and/or language of audio track
  3. IPTV set-top box (or IPTV multicast server) - tunes to the specified channel/program.
  4. Viewer – views the program.
  5. Viewer – may change the subtitle language and/or the (language of the) audio track

### 2.3.7 RECEIVE CALLER ID ON SCREEN

- **DESCRIPTION**

A viewer view media content of choice that is either:
  - broadcasted on a Pre-Subscribed Channel,
  - broadcasted in a PPV manner, or
  - delivered on demand in a VOD fashion

The viewer, then, receives a phone call and the caller ID appears on the TV screen.

- **ACTORS**
  - Viewer
  - IPTV set-top box
- **STEPS**
  1. Viewer – views media content of choice

2. IPTV set-top box – presents a caller ID on the TV screen

### **2.3.8 ALTERNATE FLOW – ADVERTISEMENT OFFER**

- **DESCRIPTION**

A viewer selects the type of advertisement s/he prefers to receive. The viewer then views media content of choice that is either:

- broadcasted on a Pre-Subscribed Channel,
- broadcasted in a PPV manner, or
- delivered on demand in a VOD fashion

An advertisement is presented on the TV screen. It can be presented either on the entire screen or on portion of the screen.

If the advertisement is multi-dimensional advertisement, the viewer may navigate within the advertisement.

If the advertisement is interactive, the viewer may interact with the advertisement, order the advertised content or asks for a sales person to contact him/her.

- **ACTORS**

- Viewer
- IPTV set-top box (or IPTV multicast/VOD server)
- IPTV PVR
- IPTV advertisement server

- **STEPS**

### 3 IPTV ACCOUNTING REQUIREMENTS

---

#### 3.1 HIGH LEVEL REQUIREMENTS OF AN IPTV ACCOUNTING

An IPTV service operator requires accounting and usage information for billing, service assurance purposes and potentially for other contractual obligations, for e.g. settlements with content partners, and reporting to rating bodies, e.g., Nielsen.

Following are the main requirements of an IPTV network accounting and usage framework:

1. Simultaneous collection of IPTV usage data from multiple IPTV network elements and correlation of the collected usage data to a given session or subscriber. Billable events are typically viewer traceable actions with financial consequences. Service reporting is largely concerned with adequately identifying service consumption events. Service consumption events are typically a superset of billable events. Service consumption events do not always have a financial consequence for the viewer, e.g. IPTV Channel change events within a pool of IPTV subscribed channels may be an example of a service consumption event which is not a billable event.
2. Highly reliable usage data collection - In general, an IPTV service provider would prefer that the IPTV service reporting data be collected securely and reliably. In many cases this may be achievable on an aggregated basis within the service provider's equipment. If network accounting and usage information (e.g., billable events) is to be used by charging and billing systems, then "high reliability" is an unspoken requirement for any potential IPTV network usage and accounting framework. High reliability in this context means that event messages are reliably conveyed from their source to their destination, regardless of the volume of traffic on the network or possible failures in the network, network elements, or downstream collectors of such records. A highly reliable framework should contain mechanisms, such as fail-over, redundant components, and unique event message IDs, that minimize the risk of lost or duplicate event messages.
3. Ability to account for IPTV usage and activities in both Real-Time and non Real-Time (Real-Time and non Real-Time are relative to when the events are sent to the mediation system and does not imply when the final bill may be available to the customer nor that events are sent to indicate incremental usage of network resources). Supporting Real-time Charging Systems that relate the events to the account balance as they occur. This may be necessary for services like, order ahead PPV (OPPV) or VOD.
4. High performance - The requirement to account for IPTV network usage and activities in real-time carries with it another unspoken requirement: high-performance. In this case, high-performance means the efficient use of capabilities of both the network and the network elements, such that the "real-time" availability of usage records is possible even in situations where both the network and network elements are stressed by a high volume of "traffic". Attaining such efficiency requires:
  - a. a concise encoding scheme, one that minimizes the size of usage records sent out on the network.
  - b. an efficient delivery protocol that minimizes the overhead involved with delivering event messages, while still enabling the reliable transfer of messages.

- c. an efficient delivery protocol that minimizes the impact that network latency can have on volume of event records that can be delivered from the various network elements to a central repository.
- 5. Flexibility and extensibility - the framework for handling network accounting and usage must also be flexible and extensible enough to support both a wide variety of IPTV based services as well as the significant number of event messages that can be generated by the diverse array of network elements supporting each such service. Furthermore, in addition to supporting possible “common denominator” or “standardized” event messages, the IPTV network accounting and usage framework may also need to support custom extensions, in the form of user defined fields in event messages. The framework also needs to be easily extensible, to be able to support future requirements imposed by new services and new technologies.

### 3.2 IPTV ENTITIES HANDLING ACCOUNTING & USAGE COLLECTION

The following IPTV entities are involved in handling of IPTV accounting and collection of usage data:

1. **The Input Device of the IPTV Receiving Device** - this entity serves as the device which: allows the viewer to select IPTV content or channel, provide a feedback on the IPTV programs, insert a text input, etc. It is typically in a form of a “remote control”, but it can also be a (wireless) keyboard or any other appropriate input device.
2. **The IPTV Receiving Device** - this entity, a.k.a. ITF (as defined in the IPTV Architecture Requirements of the ATIS IPTV Interoperability Forum), represents the functionality within the consumer network that is responsible for terminating the IP signal, and converting the content into a renderable format. It is usually a set-top box (but it can also be a DVR an IPTV-ready TV, etc) capable of functioning as a network node in an IP network.

The IPTV Receiving Device receives the viewer input, e.g., when a viewer presses on a remote control key, the IPTV Receiving Device receives a proper signal. The IPTV Receiving Device should include such functions as are necessary to support reporting on service usage patterns to the service operator. Especially the IPTV Receiving Devices supporting the IPTV services shall provide mechanisms to detect and report service consumption events that are not detectable elsewhere in the IPTV infrastructure, for example, channel change events within a pool of subscribed channels are also observable in the network and may not require specific actions at the IPTV Receiving Device.

Reporting actions may be required at the IPTV Receiving Device when content is dynamically assembled at the IPTV Receiving Device – e.g. a local insertion of advertising or the linkage to another human traceable action e.g. URL browsing. The IPTV Receiving Device functions to be supported will depend on the scope of services supported and the IPTV Receiving Device packaging. For example, an IPTV Receiving Device with integrated display capabilities may have different services supported than an IPTV Receiving Device which terminates the IPTV service, but (securely) passes the content on to a separate display device or portable media player, and hence a different set of service reporting functions. Mobile IPTV Receiving Devices may consume services in a variety of locations.

The IPTV Receiving Device should be uniquely identified by an IPTV Receiving Device ID, such as the IPTV Receiving Device MAC address (i.e., Ethernet addresses). An IP address may be dynamically assigned to the IPTV Receiving Device via DHCP, so it may change over time. Current IP addresses of the IPTV Receiving Device should be recorded for auditing purposes

3. **The IPTV Usage Data Exporter** – this entity is the IPTV network element where IPTV Service consumption events are created. In the case of telco-TV it is the network element which receives the viewer input (and other info messages) from multiple IPTV Receiving Devices. However, in certain cases, the IPTV Receiving Device itself can also be an IPTV Usage Data Exporter. The IPTV Usage Data Exporter **MUST** support periodic and event based generation of service consumption records. The IPTV Usage Data Exporter should be identified by host name or another unique string with the same FQDN format.
4. **The IPTV Usage Data Collector**

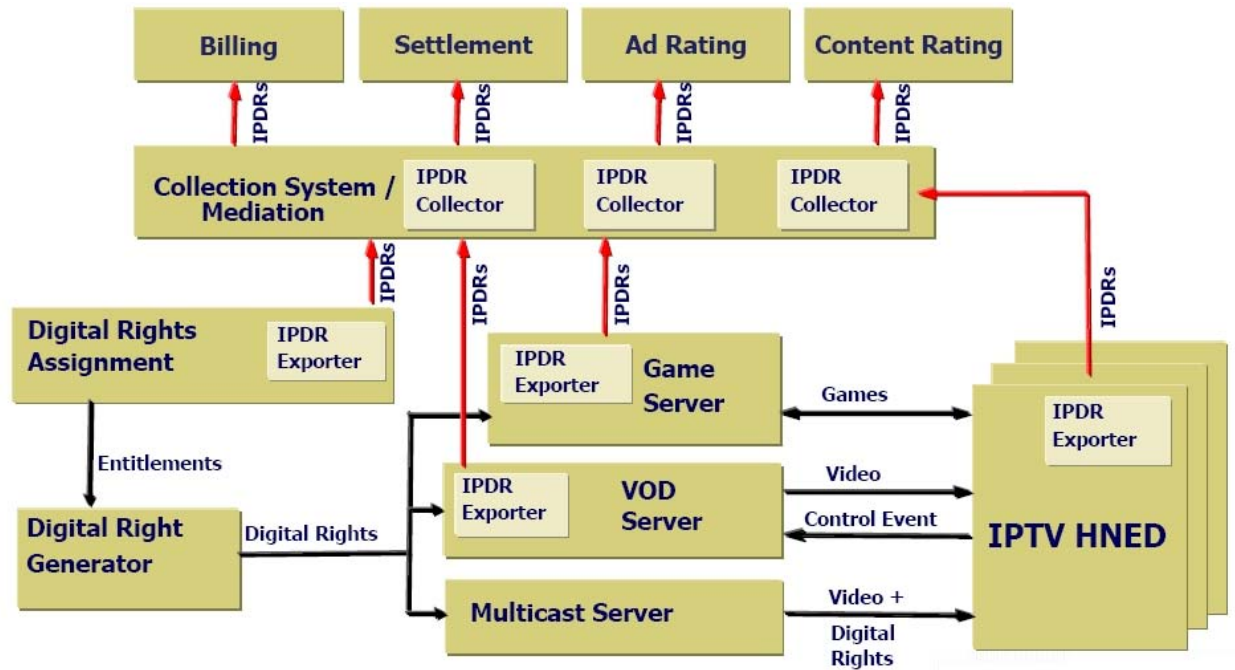

### 3.3 USAGE ATTRIBUTE LIST

IPDR records for IPTV are constructed from a number of elements that describe IPTV usage data Exporters that are serving IPTV Receiving Devices, IPTV Receiving Devices, and IPTV service attributes, counters, and viewer inputs. An IPDR element **MUST** describe a single IPTV Usage Billing Record for a single IPTV service and a single IPTV viewer.

#### 3.3.1 GENERAL IPDR ATTRIBUTES

**IPDRCreationTime**

The optional IPDRCreationTime element of the general IPDR schema is not required in IPTV IPDRs and MUST NOT be present.

#### **seqNum**

The optional seqNum element of the general IPDR schema is not required in IPTV IPDRs and MUST NOT be present

### **3.3.2 IPTV USAGE DATA EXPORTER INFORMATION**

An IPTV IPDR contains the following element that identifies the IPTV Usage Data Exporter. Each IPDR within the IPDRDoc will contain identical values for this element since all the IPDRs are based on information maintained by the same IPTV Usage Data Exporter. Note that the IPDR records of the IPTV Usage Data Exporter Information can be streamed independently from the IPTV IPDR records of the Service consumption events. These IPDR records can then be correlated at the IPTV Usage Data Collector using the IPTVExporterHostName element.

#### **IPTVExporterHostName**

IPTVExporterHostName is the fully qualified domain name (FQDN) of the IPTV Usage Data Exporter. This element is required and must not be null. If the IPTV Exporter does not have an FQDN entry in the DNS, a proper unique FQDN must be configured at the IPTV Usage Data Exporter that will serve as its identifier.

#### **IPTVExporterIpAddress**

IPTVExporterIpAddress is a non-specific version of an IP address (either v4 or v6), of type hexBinary, determined as to version by the application through lexical parsing. This is represented in the compact encoding as a 16 byte octet string.

#### **IPTVExporterSysUpTime**

IPTVExporterSysUpTime is the elapsed time (in seconds) that the IPTV Usage Data Exporter has been running since it was last started. This counter displays the difference between the start time and the current time

### **3.3.3 IPTV RECEIVING DEVICE INFORMATION**

An IPTV IPDR contains the following elements that uniquely identify the IPTV Receiving Device. Each IPTV IPDR for a given IPTV Receiving Device within the IPDRDoc will contain identical values for these elements.

#### **IPTVreceivingDeviceID**

The IPTV Receiving Device should be uniquely identified by an IPTV Receiving Device ID, such as the IPTV Receiving Device MAC address (i.e., Ethernet address formatted in hyphen '-' delimited hex notation such as a1-b2-c3-d4-e5-f6). This element is required.

#### **IPTVreceivingDeviceIpAddress**

IPTVreceivingDeviceIpAddress is a non-specific version of an IP address (either v4 or v6), of type hexBinary, determined as to version by the application through lexical parsing. It is represented in the compact encoding as a 16 byte octet string.

### 3.3.4 IPTV CONSUMER/VIEWER INFORMATION

An IPTV IPDR contains the following elements that uniquely identify the IPTV Consumer and/or the IPTV viewer Profile. Each IPTV IPDR for a given IPTV Viewer Profile within the IPDRDoc will contain identical values for these elements.

#### **IPTVconsumerID**

The IPTV Consumer should be uniquely identified by the IPTV consumer ID

This element is required

#### **IPTVviewerID**

The specific IPTV Viewer/s within a consumer household should be uniquely identified by the IPTV viewer ID

This element is optional.

#### **IPTVviewerProfileID**

The IPTV Viewer Profile should be uniquely identified by the IPTV viewer profile ID

This element is optional

### 3.3.5 IPTV RECORD INFORMATION

#### **Rectype**

The record type may have any one of the following values:

- Start - indicates the beginning of a service. A numeric value of 1 in this field indicates 'Start' service record.
- Interim - indicates a running service - An Interim service flow is reported in each IPDRDoc that is created while it is running. A numeric value of 2 in this field indicates 'Interim' service record.
- Stop - indicates a terminated service. An IPDR record of type Stop is only reported once in an IPDRDoc after the service is deleted. A numeric value of 3 in this field indicates 'Stop' service record.
- Started & Stopped - indicates a terminated service with only one IPDR record. An IPDR record of this type is only reported once in the IPDRDoc after the service is deleted. A numeric value of 4 in this field indicates 'Started & Stopped' service record

This element is required.

#### **RecCreationTime**

The RecCreationTime ="yyyy-mm-ddThh:mm:ssZ" UTC time stamp at the time the data for the record was acquired based on IPTVExporterSysUpTime value. The compact representation of this element is the 64-bit Long value since EPOCH. This element is required.

Notes: The time zone is always GMT for IPTV IPDRs

### 3.3.6 IPTV SERVICE CONSUMPTION INFORMATION

Services are the unit of billing usage data collection for an IPTV viewer. In addition, since a viewer may change their IPTV Service Package over time, it is very likely that a given viewer will have several IPDRs, one for each Service they have used during the collection period.

An IPTV IPDR contains the following elements that identify the IPTV service and contain the service attributes, viewer inputs, and counters maintained by the IPTV Usage Data Exporter for that IPTV service. Service consumption information records **MUST** be identified by IPTV Receiving Device ID but not necessarily sorted. An individual IPTV Service consumption Information record should be generated for all currently running Services as well as all terminated Services that were deleted and logged during the collection period. Note well that a provisioned or admitted service that was deleted before it became active is not recorded in the billing document.

#### **serviceIdentifier**

The serviceIdentifier element contains the service identifier (SID). This element is required and is needed to correlate the IPDRs for an individual service between adjacent IPDR records, e.g., when computing delta counters. To avoid potential confusion in the billing system, it is desirable that the IPTV Usage Data Exporter assign serviceIdentifier values with a monotonically increasing pattern.

#### **serviceType**

The serviceType element contains a numeric value that represents the type of the service associated with the service. The type of a service is one of the main IPTV services:

- Linear TV Broadcast
- VOD
- Audio broadcast
- Game
- Picture Management
- Directory service

This element is required

#### **serviceSubType**

The serviceSubType element contains a bit sequence where each bit value indicates the existence (=1) or absence (=0) of a feature that is associated with the specific service type. For example for service of type linear TV broadcast a certain bit may indicate whether the service is a live broadcast or a pre-recorded broadcast. Another bit may indicate whether a premium audio is supported or not.

This element is required

#### **channelID**

The channelID element contains the identifier of the main channel the viewer is viewing at the time of the event.

This element is required

**contentID**

The contentID element contains a unique identifier of the specific content the viewer is viewing at the time of the event.

This element is optional

**actionID**

The actionID element contains a unique identifier of the specific action the viewer performed e.g., by pressing on a specific button on the remote control in the context of the specific channel/content.

This element is optional

**viewerInput**

The viewerInput element contains a textual input given by the viewer. The viewer input is the trigger for the event. This element is optional

**3.3.7 IPTV QUALITY OF EXPERIENCE (QOE) INFORMATION**

Service reporting is also concerned with ensuring that the delivered experience is adequate, i.e., that the service delivery was achieved within acceptable performance parameters, and with the identification of failures in service delivery.

The QoE requirements for delivery of digital TV are very demanding, especially for HDTV.

The IPTV Quality of Experience specification of the ATIS IPTV Interoperability Forum describes the appropriate metrics for the IPTV Quality of Experience delivered.

The IPTV Services are metered and enforced against a Service Level Agreement (SLA) that specifies the Quality of Experience (QoE) that an IPTV operator provides to a viewer.

**Table 1 - Service Usage Element Names**

Category	Name	Type	Presence	Permitted Values	Remarks
IPTV Usage Data EXPORTER Information					
Who	IPTVExporterHostName	String	Required	e.g IPTV01.ATT.com	Refer to Section
Who	IPTVExporterIpv4Address	IPv4Addr	Required	nnn.nnn.nnn.nnn	Refer to Section
When	IPTVExporterSysUpTime	UnsignedInt	Required	32-bit integer	Refer to Section
IPTV Receiving Device Information					
Who	IPTVreceivingDeviceID	String	Required		Refer to Section
Who	IPTVreceivingDeviceIpAddresses	Ipdr:ipAddr	Required		Refer to Section 3.3.3
Who	IPTVreceivingDeviceIpv4Address	IPv4Addr	Required	nnn.nnn.nnn.nnn	Refer to Section
Consumer/Viewer Information					
Who	IPTVconsumerID	String	Required		Refer to Section
Who	IPTVviewerID	String	Required		Refer to Section
What	IPTVviewerProfileID	String	Required		Refer to Section
Record Information					
What	RecType	Enumeration	Required	Start(1)   Interim(2)   Stop(3)	Refer to Section
What	RecCreationTime	dateTimeMsec	Required	yyyy-mm-ddThh:mm:ss.mmmZ	Refer to Section
Service Consumption Information					
What	serviceIdentifier	UnsignedInt	Required	32-bit integer	Refer to Section
What	serviceType	Enumeration	Required	Linear TV Broadcast(1)   VOD(2)   Audio Broadcast(3)   Game(4)   Picture Management (5)	Refer to Section
What	serviceSubType	Unsigned Long	Required	64-bit counter	Refer to Section
What	channelID	Integer	Required		Refer to Section
What	contentID	Integer	Optional		Refer to Section
What	actionID	Integer	Optional		Refer to Section
What	viewerInput	String	Optional		Refer to Section
What	subtitleSelected	Yes/No	Optional		
What	audioTrackSelected	Yes/No	Optional		
What	languageCode	String	Conditional		ISO 639.2 Rule: Present IFF (subtitleSelected   audioTrackSelected)
What	callerIDDelivered	Yes/No	Optional		
What	advertisementOfferAccepted	Yes/No	Yes/No		
What	advertisementID	String	Conditional		Rule: Present IFF advertisementOfferAccepted
What	gameID	String	Optional		



## 4 FORMAL SPECIFICATION

---

### 4.1 SCHEMA

```

<?xml version = "1.0" encoding = "UTF-8"?>
<!--Generated by Turbo XML 2.4.1.100. Conforms to w3c http://www.w3.org/2001/XMLSchema-->
<schema xmlns = "http://www.w3.org/2001/XMLSchema"
    targetNamespace = "http://www.ipdr.org/namespaces/IPTV"
    xmlns:ipdr = "http://www.ipdr.org/namespaces/ipdr"
    xmlns:IPTV = "http://www.ipdr.org/namespaces/IPTV"
    version = "3.5-A.0.0.ID"
    elementFormDefault = "qualified"
    attributeFormDefault = "unqualified">
    <include schemaLocation = "http://www.ipdr.org/public/IPDRTypes.xsd"/>
    <import namespace = "http://www.ipdr.org/namespaces/ipdr" schemaLocation =
"http://www.ipdr.org/public/IPDRDoc3.5.1.xsd"/>
    <element name = "IPTVExporterHostName" type = "string"/>
    <element name = "IPTVExporterIpAddress" type = "ipdr:ipAddr"/>
    <element name = "IPTVExporterSysUpTime" type = "int">
        <annotation>
            <appinfo>
                <units>seconds</units>
            </appinfo>
            <documentation>
                The elapsed time (in seconds) that the Exporter has been
                running since it was last started.
                This counter displays the difference between the start time
                and the current time.
            </documentation>
        </annotation>
    </element>
    <element name = "IPTVreceivingDeviceID" type = "string"/>

```

```
<element name = "IPTVreceivingDeviceIpAddress" type = "ipdr:ipAddr"/>
<element name = "IPTVsubscriberID" type = "string"/>
<element name = "IPTVviewerID" type = "string"/>
<element name = "IPTVviewerProfileID" type = "string"/>
<element name = "RecType">
  <simpleType>
    <restriction base = "int">
      <enumeration value = "1">
        <annotation>
          <appinfo>
            <ipdr:enumMeaning>
              Start
            </ipdr:enumMeaning>
          </appinfo>
        </annotation>
      </enumeration>
      <enumeration value = "2">
        <annotation>
          <appinfo>
            <ipdr:enumMeaning>
              Interim
            </ipdr:enumMeaning>
          </appinfo>
        </annotation>
      </enumeration>
      <enumeration value = "3">
        <annotation>
          <appinfo>
            <ipdr:enumMeaning>
              Stop
            </ipdr:enumMeaning>
          </appinfo>
        </annotation>
      </enumeration>
    </restriction>
  </simpleType>
</element>
```

```

    </appinfo>
  </annotation>
</enumeration>
<enumeration value = "4">
  <annotation>
    <appinfo>
      <ipdr:enumMeaning>
        Started and Stopped
      </ipdr:enumMeaning>
    </appinfo>
  </annotation>
</enumeration>

</restriction>
</simpleType>
</element>
<element name = "RecCreationTime" type = "ipdr:dateTimeMsec"/>
<element name = "serviceIdentifier" type = "int"/>
<element name = "serviceType">
  <simpleType>
    <restriction base = "int">
      <enumeration value = "1">
        <annotation>
          <appinfo>
            <ipdr:enumMeaning>
              Linear TV Broadcast
            </ipdr:enumMeaning>
          </appinfo>
        </annotation>
      </enumeration>
      <enumeration value = "2">

```

```
<annotation>
  <appinfo>
    <ipdr:enumMeaning>
      VOD
    </ipdr:enumMeaning>
  </appinfo>
</annotation>
</enumeration>
<enumeration value = "3">
  <annotation>
    <appinfo>
      <ipdr:enumMeaning>
        Audio Broadcast
      </ipdr:enumMeaning>
    </appinfo>
  </annotation>
</enumeration>
<enumeration value = "4">
  <annotation>
    <appinfo>
      <ipdr:enumMeaning>
        Game
      </ipdr:enumMeaning>
    </appinfo>
  </annotation>
</enumeration>
<enumeration value = "5">
  <annotation>
    <appinfo>
      <ipdr:enumMeaning>
        Picture Management
      </ipdr:enumMeaning>
    </appinfo>
  </annotation>
</enumeration>
```

```

        </ipdr:enumMeaning>
    </appinfo>
</annotation>
</enumeration>
<enumeration value = "6">
    <annotation>
        <appinfo>
            <ipdr:enumMeaning>
                Directory
            </ipdr:enumMeaning>
        </appinfo>
    </annotation>
</enumeration>
</restriction>
</simpleType>
</element>
<element name = "serviceSubType" type = "long"/>
<element name = "channelID" type = "int"/>
<element name = "contentID" type = "int"/>
<element name = "ActionID" type = "int"/>
<element name = "viewerInput" type = "string"/>
<element name = "subtitleSelected" type = "int"/>
<element name = "audioTrackSelected" type = "int"/>
<element name = "languageCode" type = "string">
    <annotation>
        <documentation>
            <appinfo>
                <ipdr:reference>
                    http://www.loc.gov/standards/iso639-2/langcodes.html
                </ipdr:reference>
            </appinfo>
        </documentation>
    </annotation>
</element>

```

```

</documentation>
</annotation>
</element>
<element name = "callerIDDelivered" type = "int"/>
<element name = "advertisementOfferAccepted" type = "int"/>
<element name = "advertisementID" type = "string"/>
<element name = "gameID" type = "string"/>
<complexType name = "IPDR-IPTV-Type">
  <complexContent>
    <extension base = "ipdr:IPDRType">
      <sequence>
        <element ref = "IPTV:IPTVExporterHostName"/>
        <element ref = "IPTV:IPTVExporterIpAddress"/>
        <element ref = "IPTV:IPTVExporterSysUpTime"/>
        <element ref =
          "IPTV:IPTVIPTVreceivingDeviceID"/>
        <element ref =
          "IPTV:IPTVIPTVreceivingDeviceIpAddress"/>
        <element ref = "IPTV:IPTVsubscriberID"/>
        <element ref = "IPTV:IPTVviewerID"/>
        <element ref = "IPTV:IPTVviewerProfileID"/>
        <element ref = "IPTV:RecType"/>
        <element ref = "IPTV:RecCreationTime"/>
        <element ref = "IPTV:serviceIdentifier"/>
        <element ref = "IPTV:serviceType"/>
        <element ref = "IPTV:serviceSubType"/>
        <element ref = "IPTV:channelID"/>
        <element ref =
          "IPTV:contentID" minOccurs = "0"/>
        <element ref =
          "IPTV:ActionID" minOccurs = "0"/>
        <element ref =

```

```
        "IPTV:viewerInput" minOccurs = "0"/>
    <element ref =
        "IPTV:subtitleSelected" minOccurs = "0"/>
    <element ref =
        "IPTV:audioTrackSelected" minOccurs = "0"/>
    <element ref =
        "IPTV:languageCode" minOccurs = "0"/>
    <element ref =
        "IPTV:callerIDDelivered" minOccurs = "0"/>
    <element ref =
        "IPTV:advertisementOfferAccepted" minOccurs = "0"/>
    <element ref =
        "IPTV:advertisementID" minOccurs = "0"/>
    <element ref =
        "IPTV:gameID" minOccurs = "0"/>
    </sequence>
</extension>
</complexContent>
</complexType>
</schema>
```

## 4.2 SAMPLE INSTANCE DOCUMENT