



**IPDR
Business Solution Requirements –
Network Data Management-Usage (NDM-U)**

Version 3.5.0.1

November, 2004

© 1999-2004 IPDR.org, Inc.

Preface

Abstract

In order to develop the IPDR business solutions, it is required that a requirements framework be in place that formally classifies the “IP network and service elements” and “support systems.” Next, the relationship between such subsystems needs to be in place to determine the flow of information between components. Finally, the requirements of each subsystem must be determined in order to specify the type of “IP resource and service usage information” that will be exchanged.

This document is comprised of two major sections: 1) Reference Model, and 2) Requirements. This information is then used to develop design guidelines for the specification of various IP-based services and to design a protocol for the encoding and transport of accounting and settlement information.

Note that all references, terminology, and glossary of terms are contained in a common document component—IPDR References and Terminology, applicable across all IPDR documents.

Change History

3.5 ID	7/10/03—Initial Draft for Working Group Review
3.5 RD1	9/17/03—Review Draft 1
3.5	May 4, 2004—Production Release
3.5.0.1	November, 2004—“Cosmetic” Cleanup Release

Table of Contents

Preface	2
Abstract.....	2
Change History	2
1. Introduction	4
1.1 Purpose	4
1.2 Scope	4
1.3 Compatibility	4
1.4 Overview	4
1.4.1 Document Overview	4
1.4.2 Revision Numbering Structure	5
2. IPDR Reference Model.....	6
2.1 IPDR and the TMF Model.....	6
2.2 IPDR High-level Model.....	8
2.3 IPDR Information Content	10
2.4 The IPDR Reference Model	10
2.4.1 IPDR Nodes	11
2.4.2 IPDR Interfaces	13
2.5 IPDR Model Usage Scenarios	16
2.5.1 SE Directly Interfaced to BSS	16
2.5.2 SE Interfaced to BSS Via Mediation System.....	17
2.5.3 SE Interfaced to BSS via Multiple Mediation Devices.....	17
2.5.4 Simple Roaming with Separate Access and Home Service Providers.....	18
2.5.5 Service Provider also Provides an Application Service	18
2.5.6 Separate Home, Access, Transport, and Application Service Providers Acting in Concert	20
2.5.7 Content Delivery Use Case.....	23
2.5.8 Specific Usage Scenario – WiFi Roaming.....	25
3. Requirements	28
3.1 Introduction	28
3.2 Assumptions	29
3.3 Detailed Requirements	30
3.3.1 Mediation.....	30
3.3.2 BSS	30
3.3.3 Format.....	30
3.3.4 Application Protocol.....	31
3.3.5 Usage Attributes	31
3.3.6 Settlement	32
3.3.7 IPDR Common Data Elements – Application “Envelope”	32
3.4 Listing of Services.....	33
3.4.1 Services Covered	33
3.4.2 Services Considered by other Organizations	33
3.5 Quality of Service (QoS) Metric Guidelines	34
3.5.1 QoS Metrics – General	34
3.5.2 Categories of Quality of Service and Network Performance Metrics.....	34
3.5.3 Survey of Standardized QoS Metrics.....	35
3.5.4 QoS Classes and Performance Objectives	37
4. IPDR Information Metamodel.....	38
4.1 IPDR Master Schema	39
4.2 Annotated IPDR Master Schema.....	42

1. Introduction

1.1 Purpose

This document, in conjunction with the referenced Service Definition documents, is intended to specify technical information that is sufficient for practical implementations of interchange of usage data among service elements participating in the delivery of IP-based services, either within a single enterprise or across multiple enterprises.

The IPDR organization (IPDR.org) intends to submit this specification to selected accredited organizations for consideration as an approved standard.

1.2 Scope

This document is limited to the discussion of issues as defined by the mission statement of IPDR.org, namely:

“The IPDR Organization (the “Organization”) is organized and operates as a non-stock not for profit organization for the following purposes:

- To create and promote the adoption of interoperability standards for exchanging service usage and control information between IP network or hosting elements and operations or BSSs

To provide a standardized framework for the development of carrier-grade support systems that enable next-generation digital service providers to operate efficiently and cost effectively.”

1.3 Compatibility

Future revisions are expected to make every attempt to preserve investments made by service providers and solution vendors by considering backward and forward compatibility whenever it is practical. This version represents the culmination of over five years of project work by the Working Groups, resulting in a fully-featured production-grade design, accompanied by working reference code libraries in Java and C implementing the full specification. As design adoptions and production applications of this technology are put into service in actual commercial situations, the issue of compatibility takes on a new level of criticality. IPDR.org fully intends to protect and preserve the compatibility of uses of its technology for the foreseeable future. Should the membership decide that significant features should be added, resulting in a subsequent version, backward compatibility will be a paramount consideration.

1.4 Overview

1.4.1 Document Overview

This specification is divided into three major chapters:

- IPDR Reference Model - a definition of the abstract and operational relationships between entities involved in the generation, recording, storage, transport, and processing of usage attributes.

- Business Requirements - a definition of business requirements to be addressed by the protocol specification and specific scenarios for the major process flows anticipated in actual application.
- Information Metamodel – the abstract definition of the generic IPDR Document.

1.4.2 Revision Numbering Structure

The version number of this document is structured in the form M.m, where “M” is a major change in requirements and technology content, “m” is a minor change within the scope of the requirements and technology of the major release.

2. IPDR Reference Model

IPDR.org has adopted the TeleManagement Forum’s (TMF) Enhanced Telecommunications Operations Map (eTOM) for the purposes of motivating the functional role and interfaces of the IPDR specifications relative to operations support systems (OSS). We have chosen the eTOM because it is a well-known, industry-accepted organizational model of telecommunications operations business processes used by carriers and service providers today. The TMF Model is useful as a model of typical systems, and as motivation for design decisions. However, the TMF Model itself is not part of IPDR, and the data structures and interfaces of IPDR may be used in systems that vary substantially from the TMF Model. See [1] for more details.

2.1 IPDR and the TMF Model

The eTOM, shown in Figure 1 and the TOM, shown in Figure 2, identify the core operation support processes found in a production carrier business operation. The systems that implement the customer care, services development/operations and network/systems management processes each provide a well-defined set of services that enable a carrier to successfully deploy and manage telecommunications services. As the model shows, these systems are organized in a layered fashion. Thus, each component builds on the services provided at a lower layer (and possibly adjacent components) to deliver the required functionality. IPDR.org’s charter is to facilitate the integration of IP-based network elements into billing, reporting and assurance systems. In particular, one key goal is to define a common usage record format and exchange protocol to facilitate the flow of usage information from IP network elements managers to support systems. In the eTOM, the network data management (NDM) component (defined as part of the network and systems management processes) defines the device-independent collection mechanism for such purposes. As such, the work of this specification falls primarily within the domain of the NDM component.

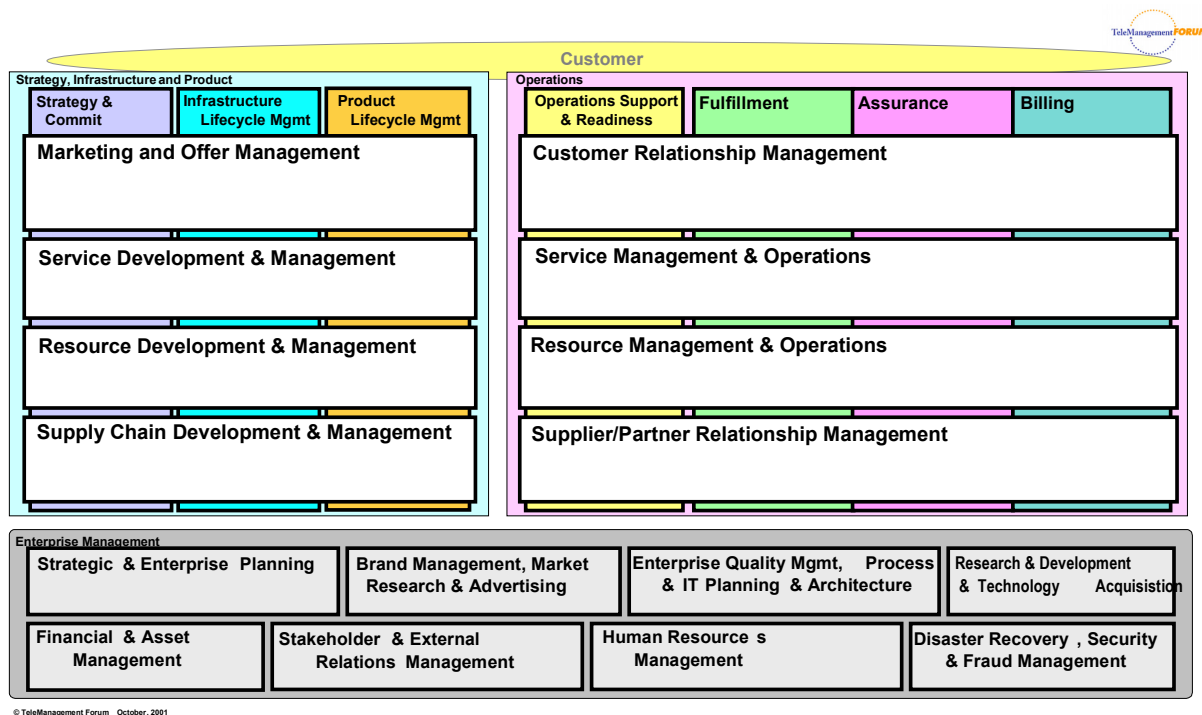

Figure 1: eTOM Business Process Framework—Level 1 Processes

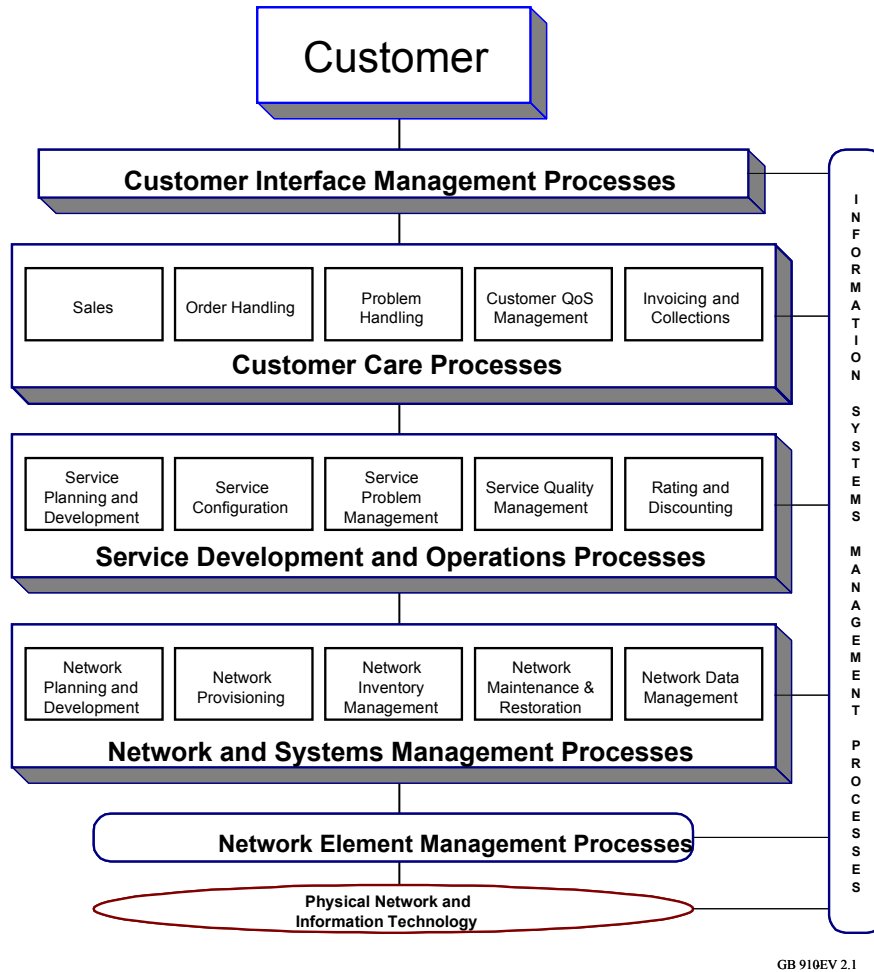

Figure 2: Telecommunications Operations Map (TOM)

2.2 IPDR High-level Model

Within the scope of the NDM module, the eTOM assumes interfaces to billing (i.e., rating and discounting) and customer care systems (i.e., service quality management and problem resolution). Likewise, the eTOM assumes that the NDM component must interface directly with the network and service element manager to accomplish their various services.

The IPDR reference model, shown in Figure 3, expands on the TOM definition by dividing the module into layers; namely: (1) the network and service element layer, (2) the mediation layer, and (3) the business support systems (BSS) layer. Each layer is discussed below:

Network and service element layer (NSE): The NSE layer consists of all the network and service elements required to provide an IP-based service to a given customer. For example, routers, access devices, and transmission facilities together provide basic connectivity; firewalls might provide a security service; email, file, and print servers provide application services; gateways provide a translation service from circuit to packet voice; and more. In addition to physical devices, the systems that configure and manage such devices are considered part of the NSE layer (note, that this functionality is identified as adjacent component within the “Network and Systems Management” layer in the TOM model). Examples here include a bandwidth management system, H.323 gatekeeper, RADIUS, authentication server or network management platform.

Mediation layer: As shown in Figure 3, mediation systems sit between the network elements/infrastructure and the BSSs. Typically, a mediation system provides a single interface to BSSs that provides all network usage data and often a single interface for service elements provisioning. In terms of usage collection, the goal of the mediation system is to capture all usage information required by the BSSs, and export it within the temporal requirements. Thus, the mediation system must determine the devices at the service element layer and interface with that infrastructure to extract the relevant usage information. The second mediation goal is to pass provisioning information from the BSS, to the network elements – again, within the temporal constraints.

- ◆ *Business support systems (BSS) layer:* The BSS layer consists of the systems deployed by a service provider or provider to support IP business operations. This layer corresponds to the “Systems Development and Operation Processes” and “Customer Care Processes” in the TOM model. Some examples include billing (i.e., rating and discounting), customer care/relationship management, decision support, and market analysis and fraud detection. The BSS layer is the highest layer in the model. Thus, the BSS usage collection and provisioning requirements drive the mediation system and ultimately the services provided at the service element layer.

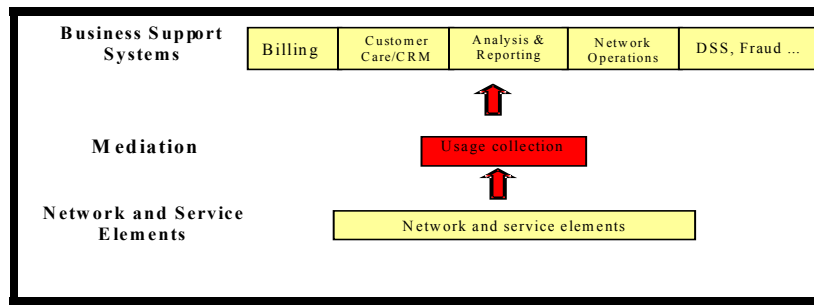

Figure.3: IPDR High-Level Model

The IPDR model shown in Figure 3 gives a layered perspective of the components and interfaces designed to meet the IPDR business solutions requirements. The usage collection process represents a flow of usage data from the network and service elements to the BSS processes. The mission statement given in the introduction limits the organization’s current scope to the usage collection path (shown flowing upward in Figure 3). Thus, provisioning or the internal design of any of the identified components is not considered in this document.

Figure 4 illustrates the usage data path from network elements (e.g., gateways, remote access servers (RAS), routers, and bandwidth managers) to a mediation device in a typical IP network scenario. Note that this example assumes the interface between the mediation device and network elements is based on a proprietary access protocol, record format and API. The mediation system aggregates, normalizes and correlates the usage data as required, and exports the data to the billing, decision support, or other BSSs.

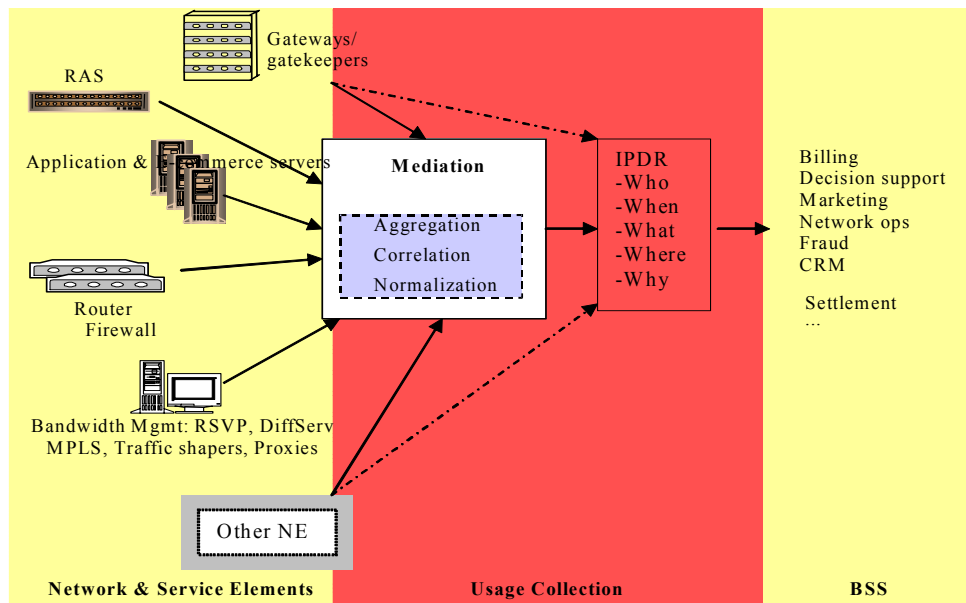

Figure 4: IPDR Record Flow Example

The IPDR model plays several roles in this data transfer. First, the IPDR record provides flexible structure that is sufficiently powerful to describe the usage attributes collected by the mediation system, and required by the BSS. Second, the IPDR model provides a set of interfaces that facilitate the exchange of IPDR records between mediation systems and BSSs, or potentially between IP network elements and BSSs (as demonstrated by dotted lines). Finally, the IPDR

specification provides a common format that facilitates the intermediate storage of IPDR records between IPDR-enabled components.

2.3 IPDR Information Content

The IPDR must be capable of characterizing any type of usage that might be collected from an IP-based network or application service. As Figure 4 identifies, there are five attributes common to typical IPDR records. Broadly, these components are the “who, what, where, when and why” values that describe a particular usage event. Each is described briefly below (formal definitions are provided in a later chapter):

- {Who} (Responsible for the usage)
User ID
- {When}
End Time or Event Time
- {What}
Service
Usage measures / quantities
Ex: Bytes, packets, flows, hits, transactions, time duration...
QoS measures
State information
Event code (logon, logoff, threshold exceeded)
Other information about state transition or current state (Start Time)¹
- {Where}
Traceability / Context
Source Identifier
Destination Identifier
Service Element identifier (originator)
- {Why} Event trigger type – (i.e., why is the network and service element reporting this data?)

In addition to the “5Ws” defined above, each record may include reference pointers to other IPDR records that either capture related usage information, or contain usage information that was used to create the given record.

2.4 The IPDR Reference Model

In addition to the IPDR structure, the IPDR specification defines a set of interfaces for exchanging IPDRs between IPDR-enabled devices or systems. As is specified in the Service Specification Design Guidelines, IPDRs are packaged in protocol data units (PDUs) known as IPDR Documents (IPDRDocs). These PDUs are the entities for which protocol transactions and tracking are done. All future references to IPDR documents imply these formal protocol entities. Figure 5 shows the key interfaces and elements found within the IPDR reference model, represented in an abstract form. For instance, a product solution might be developed that acts as

¹ Note that “always on” services may be measured via periodic emission of IPDRs, recording usage since the last interval boundary.

the "generator"/"sensor" of usage data by means of passive monitoring of IP packet streams, packaging sets of this data into IPDRDocs for forwarding to BSSs. Such a packaging of functionality would internalize the A, B, and C interfaces, presenting to the "outside" only the D interface. Another "sensor"-only product might accept proprietary-format records of usage data from a "generator" SE that offers such records via an FTP-based A interface and offers them to BSSs via an IPDR-compliant D interface. Both implementations are equally valid and might offer different value propositions to various SPs looking for a usage solution. Note that this model does not constrain implementations to be physically packaged as portrayed, nor to present all of the interfaces to other systems.

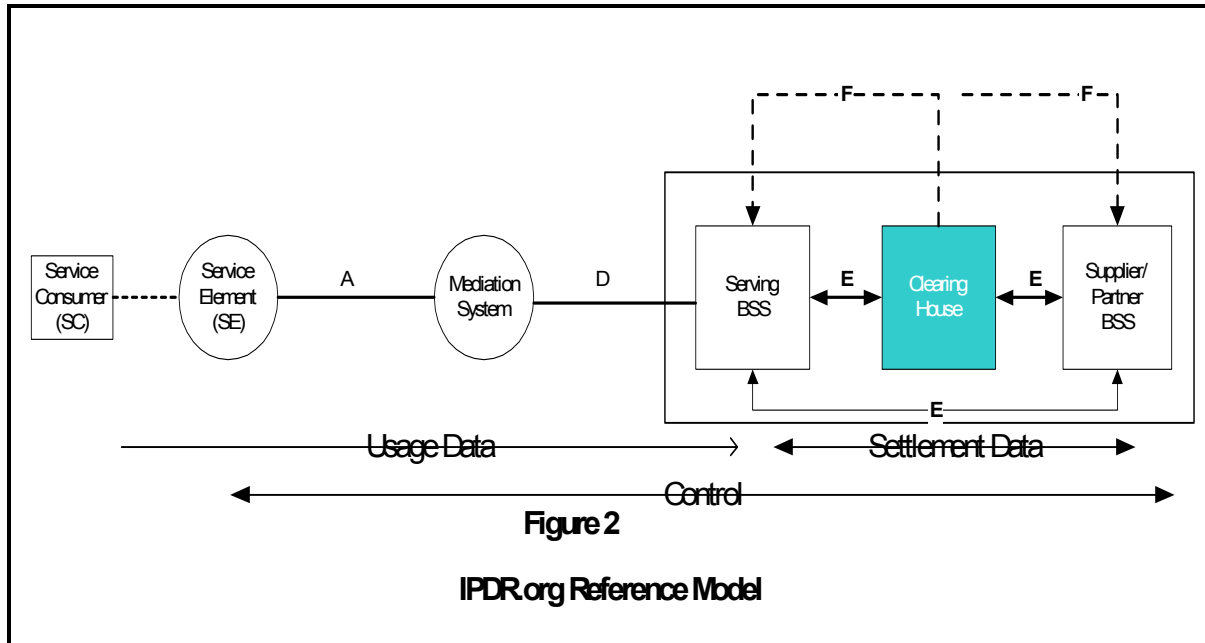

Figure 5: IPDR Reference Model

This document focuses on the definition of IPDR Documents, the information content of IPDRs and the interface between ITs and BSSs. The D interface is completely specified in this document while other interfaces are identified here to aid in decomposing the problem statement.

Implementations adhering to this version of THE SPECIFICATION are not required to explicitly separate the IPDR Recorder, IPDR Store and IPDR Transmitter roles, since the B and C interfaces are, as of this release, unspecified. Similarly, the E interface is not explicitly addressed in this release of the SPECIFICATION. As of this writing, IPDR.org working groups are beginning to address E interface. The E interface discussion will specify detailed requirements and design (at least for IPDR-IPDR exchange scenarios).

2.4.1 IPDR Nodes

2.4.1.1 Service Consumer (SC)

This is the human or machine initiating requests for services from the Service Element (SE). The Service Consumer requesting and receiving service is typically the end user on end system.

Note that an SC may request services from an SE via another SE that is providing access to the Internet, thus involving more than one SE in the providing of a given service.

2.4.1.2 Service Element (SE)

This is the set of equipment and software that provides a valuable service to a Service Consumer. The Service Element provides access to services and a requested resource, authenticates Service Consumers, authorizes access, performs accounting measurement for resources provided, provides services requested by Service Consumer, and performs accounting measurement for services provided. Many classes of Service Elements exist: Network routers, VOIP switches servers, ASP applications servers, etc. The IPDR reference model applies to any type of Service Element that is capable of generating accountable usage records (i.e. a record of which services were provided to which consumers). An SE is a generalized superset of Network Elements (NE).

2.4.1.3 IPDR Recorder (IR)

This entity performs two principal functions: 1) Mediating proprietary protocols and data transactions from a Service Element; and 2) Producing IPDRs resulting from the transformation of that proprietary data. IPDR Recorder packages usage information into IPDRs, it presents a stream of IPDRs to an IPDR Store and/or an IPDR Transmitter. Multiple Service Elements can be connected to a single IPDR Recorder.

2.4.1.4 IPDR Store (IS)

This is the entity that provides persistence to the IPDRs recorded by an IPDR Recorder. The IPDR Store receives IPDRs from an IPDR Recorder and packages them into IPDR documents stored in a non-volatile medium. The IS, also, provides a repository of IPDRDocs for transmission or retransmission of selected IPDRDocs by the IPDR Transmitter to one or more BSSs. An IPDR Store can receive IPDRs from one or more IPDR Recorders and the IS can deliver IPDRDocs to one or more IPDR Transmitters.

2.4.1.5 IPDR Transmitter (IT)

The IPDR Transmitter delivers IPDR documents to BSSs. These documents may be retrieved from an IPDR Store, or they may be created directly by the IT. This entity performs three principal functions: 1) Packaging of IPDRs from the IPDR Recorder into IPDRDocs; 2) Organization of IPDRDocs containing usage of the same service type into Groups; and 3) Transmission (or retransmission) of IPDRDocs from Groups to one or more BSSs, using one of a set of transfer protocols. An IPDR Transmitter can deliver IPDRDocs to one or more BSSs.

2.4.1.6 Business Support System (BSS)

This entity is any system that implements a technical or commercial function to perform one or more processes in a telecommunications enterprise. A BSS receives information contained in IPDRDocs from an IPDR Transmitter, processes the information contained in the contained IPDRs for use in the commercial activities of a service provider, and presents information for transmittal to other BSSs. A BSS can receive IPDRDocs from one or more IPDR Transmitters.

2.4.2 IPDR Interfaces

2.4.2.1 *A Interface*

The A interface delivers usage information from Service Elements to IPDR Recorders. The IPDR does not attempt to constrain the file naming conventions, format, transfer protocol, sequencing, or other details of the A interface data transfer mechanism. It is not assumed to be real-time nor batch.

An A interface receives data generated by a Service Element. At the present state of the industry, this is typically a vendor-specific access protocol – often file-based, but sometimes CORBA, HTTP, or socket-based. It typically includes high-volume data at a highly detailed granularity. However, the data is often very equipment-level in detail (e.g., port number, IP address, or line number). Much of the A interface data may require translation before it can be related to business-level entities (e.g., customer and price plan).

In addition to being equipment-level in detail, data transferred on the A interface is often incomplete for business purposes. For example, interim usage details are common. Interim usage details are describing a service delivery event that cannot be correctly interpreted without context provided by other data. For example, “Start Call” and “Stop Call” entries must be correlated to each other in order to determine call length. Other examples of interim entries might be: Start Application, Service Query, Connect additional line to conference, Drop line from conference, Convert text message to voice, etc.

Communication at this granular level and correlation/translation into useful business-level identifiers is a core competency of mediation packages. THIS SPECIFICATION assumes the communication, translation, and correlation to be revenue-grade.

The IPDR.org may comment on the data elements required by the A interface for specific services. Such comments are contained in the “Assumptions for other interfaces” section of the Service Specifications.

Not all requirements inherent to the A interface are well supported by the IPDR standard. However, some types of equipments (e.g. application servers) are good candidates for generating usage data using IPDR format and protocols. It is, therefore, possible for Service Elements to generate data in an IPDR compliant format. Such an interface will be identified as an A interface with an IPDR compliant data format.

Typical requirements for the A interface (observed by the implementations of SE vendors, but not necessarily by IPDR) are:

- Minimum encoding complexity
- Convenience of data collection and record construction
- Minimum data size
- Minimum imposition of data storage requirements on the SE
- Support for custom vendor features and capabilities

2.4.2.2 B Interface

The B interface delivers IPDRs from IPDR Recorders to IPDR Stores and to IPDR Transmitters. The payload conforms to the schema definition of an IPDR. As of this issue of the SPECIFICATION, the transfer protocol for this interface is not specified.

2.4.2.3 C Interface

The C interface delivers IPDR documents from the IPDR Store to the IPDR Transmitter. Each IPDRDoc contains one or more IPDRs from a particular Service Element served by a given IPDR Recorder. As of this issue of the specification, the transfer protocol for this interface is not specified.

2.4.2.4 D Interface

The D interface delivers IPDR documents from IPDR Transmitters to BSSs. The transfer protocol on this interface is specified in the Protocol documents of the IPDR document set.

2.4.2.5 E Interface

The E interface delivers IPDR documents from one BSS to another BSS. Various scenarios of providing service can be anticipated which will involve a combination of transport technologies and multiple service providers. In such scenarios, the business relationships involved will require the exchange of usage data for a variety of business process applications (e.g., net settlement, retail bill detail, customer service, fraud abatement, marketing studies). The interface dedicated to such exchange is the E interface. For IPDR-compliant service providers, the data exchanged may very well be IPDRDocs being delivered via some variant of the D interface protocol. In hybrid cases, the sending or receiving system may have to mediate the data format and protocol from or to an IPDR-compliant form. Other industry standards and practices will require mappings with respect to IPDR for this to be implemented. The definition of the details of the E interface will address this requirement.

Note that this document focuses on the definition of IPDR Documents, the information content of IPDR records and the interface between ITs and BSSs. The D interface is completely specified in this document while other interfaces are identified here to aid in decomposing the problem statement. Implementations adhering to this version of THE SPECIFICATION are not required to explicitly separate the IPDR Recorder, IPDR Store and IPDR Transmitter roles, since the B and C interfaces are unspecified. Similarly, interfaces A and E are not explicitly addressed in this release of the NDMU. As of this writing, IPDR working groups are beginning to address interfaces A and E.

The E interface delivers IPDR documents from one BSS to another BSS. Various scenarios of providing service can be anticipated which will involve a combination of transport technologies and multiple service providers. In such scenarios, the business relationships involved will require the exchange of usage data for a variety of process applications (e.g., net settlement, retail bill detail, customer service, and fraud abatement, marketing studies). The interface dedicated to such exchange is E interface. For IPDR-compliant service providers, the data exchanged may very well be IPDRDocs being delivered via some variant of the D interface protocol. In hybrid cases, the sending or receiving system may have to mediate the data format

and protocol from or to the IPDR compliant form. Other industry standards and practices will require mappings with respect to IPDR for this to be implemented. The definition of the details of the E interface will address this requirement.

BSS / Settlement System

The Settlement System will interface with other BSSs for the purpose of exchanging relevant third party service provider rating and settlement related information.

All the events rated / re-rated by the retail billing system and relevant for settlement system are passed to the Settlement System.

The Settlement System may subsequently communicate with the retail billing system for all events (credit transactions) that are end user or service consumer related.

Settlement System / Other Systems (*Note: Currently Outside Scope of S/PS*)

The Settlement System will need to interface with various other Supplier/Partner BSSs including, but not limited to Financial Systems for third party service provider's accounts receivable information, Electronic invoice, and Document management systems.

Settlement system will interface with CRM system for point-of-sale service and /or order management for consumer events. CRM system can be alternate BSS source to Settlement system other than Retail Billing system for data related to service consumer.

Settlement system will interface with financial systems for third party service provider's Accounts Payable transaction information.

Settlement system will interface with Banks and any other financial agencies for EFT (electronic fund transfer) and exchange rates information.

In addition, Settlement system may interface with other BSSs including, but not limited to the above mentioned BSS that can be source of input data for settlement solution.

While the current focus of this specification places these other interfaces and transactions outside its scope, at a minimum the existence and requirements of such other interfaces will be accounted for to ensure the practicality of this specification. If no other body of work on these other interfaces exists and it is considered necessary to discuss them in more detail, the scope of this specification could be expanded to include them, based on the decision of IPDR.org.

2.5 IPDR Model Usage Scenarios

The focus for specifying requirements is given to D interface though there may be implied requirements to other interfaces. Section 3 provides general requirements and general usage attributes applicable to any IP service. Note that any new IP service added in the future may impact the general requirements and usage attributes. Section 0 provides IP services covered and yet to be covered in this chapter.

A number of assumptions are made in the following usage scenarios:

- Home Service Provider handles all business needs (via BSS applications) of the Service Consumer.
- Service Consumer may or may not be within the Home Service Provider's service area.
- BSS to BSS interfaces (E Interface) is outside the scope of this version of the specification.

Some applications of IPDR will result in large numbers of IPDRs being generated, requiring economical storage, transport, and processing implementations. Several requirements stated below are intended to address this assumption. However, no quantitative requirements regarding performance (end-to-end delay, transfer rate, etc.) or efficiency (message size, compression ratio, etc.) will be stated in this document. The mechanisms designed in later chapters of this document, which satisfy the general requirements in this area, should give implementers adequate tools to make cost versus technology tradeoffs, justified in light of the business problem being solved. Product vendors designing implementations of this specification are assumed to be aware of the overall marketplace requirements for such systems and service providers selecting one or more of these implementations will be expected to require those vendors to demonstrate competitive features in the area of performance.

2.5.1 SE Directly Interfaced to BSS

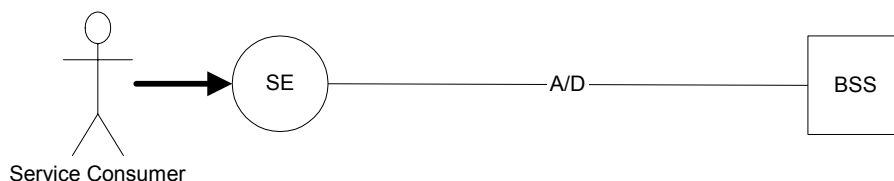

Figure 6: SE Directly Interfaced to BSS

A service element (SE) can directly interface with the BSS. If an SE node supports the D interface specifications including backing stores and the retransmission of IPDR documents, then the SE node can communicate directly with the BSS node. The IR, IS, and IT nodes do not necessarily have to be independent system entities. In this case the IR, IS, and IT nodes are incorporated within the SE node.

2.5.2 SE Interfaced to BSS Via Mediation System

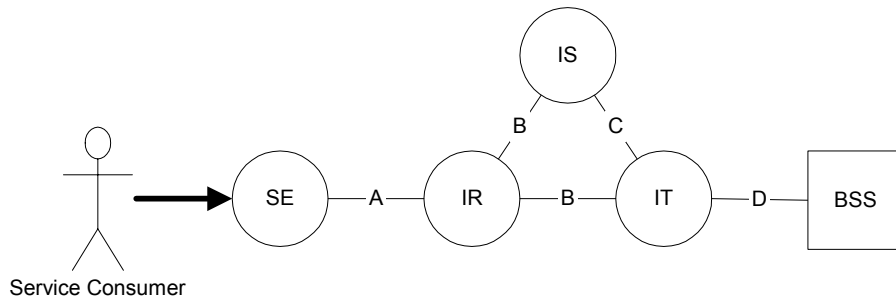

Figure 7: SE Interfaced to BSS via Mediation System

When an SE node provides a proprietary usage record interface or when it cannot provide record aggregation or it does not provide record retransmission capabilities, then an external IPDR compliant mediation system is required. The IPDR mediation system provides an interface to the SE node's proprietary protocol via the A interface, provides the required IPDR D interface protocol, and it provides an IPDR backing store for re-transmitting the IPDR records to the BSS. This is the traditional IPDR topology.

2.5.3 SE Interfaced to BSS via Multiple Mediation Devices

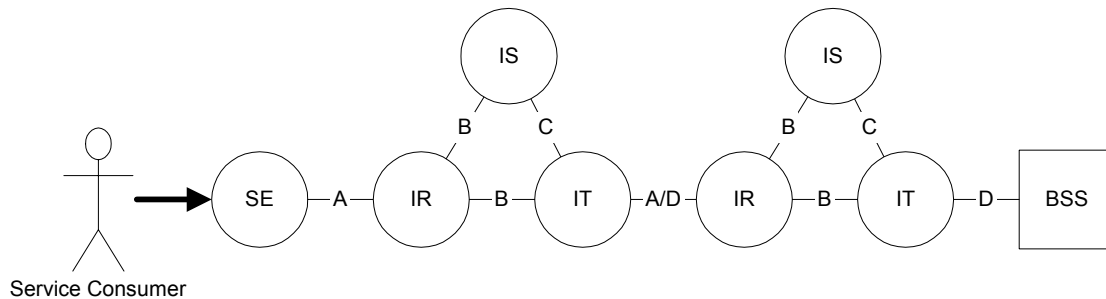

Figure 8: SE Interfaced to BSS via Multiple Mediation Devices

In some cases due to legacy mediation systems or for other reasons, more than one mediation system may be cascaded between the SE and BSS nodes. Two cases arise. In one case Mediation system 1 can transmit IPDRs to Mediation system 2 using the D interface protocol. In another case, if both mediation systems know a common proprietary protocol, compliant to the A interface specifications they can use that interface. In the former case, both mediation systems need to be IPDR compliant, while in the later case only the second mediation systems needs to be IPDR compliant. This illustrates the A interfaces requirement for being protocol compatible with the D interface.

2.5.4 Simple Roaming with Separate Access and Home Service Providers

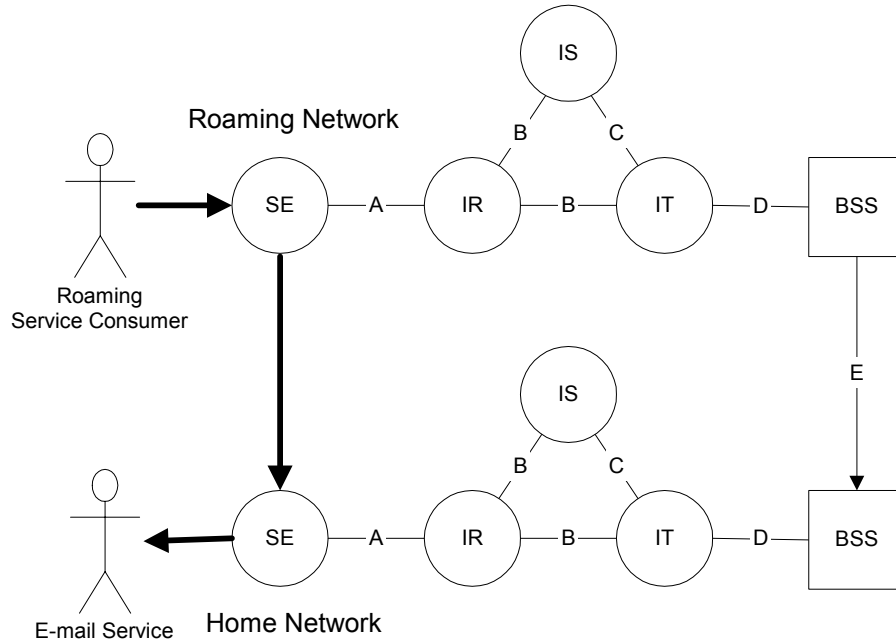

Figure 9: Simple Roaming with Separate Access and Home Service Providers

If an ISP offers roaming to its subscribers then the cooperating roaming ISP needs to be able to deliver its roaming IPDR settlement records to the home ISP BSS. This is implemented over the IPDR defined E interface. IPDR settlement records may be transmitted directly between participating BSSs as illustrated here, or they may communicate via an intermediate clearing house BSS. In either case, the settlement records are exchanged via the IPDR E interface protocol standard.

2.5.5 Service Provider also Provides an Application Service

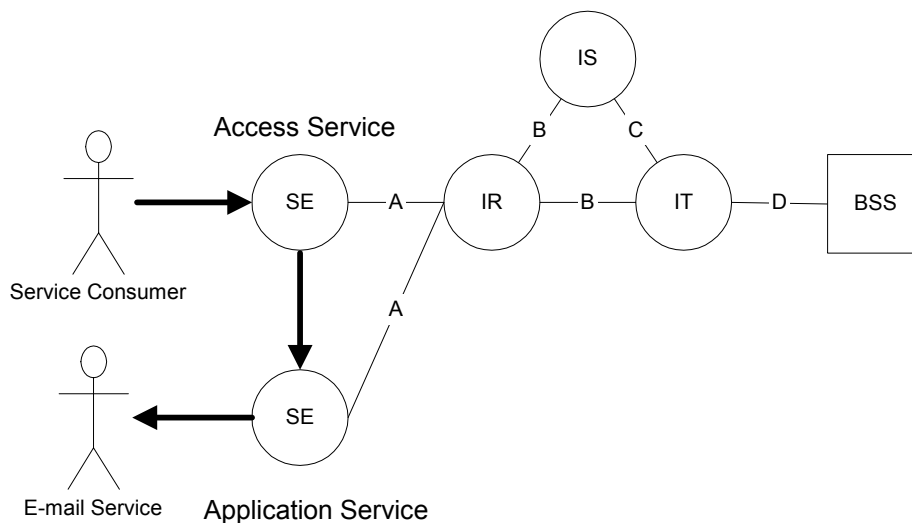

Figure 10: Service Providers also Provides an Application Service

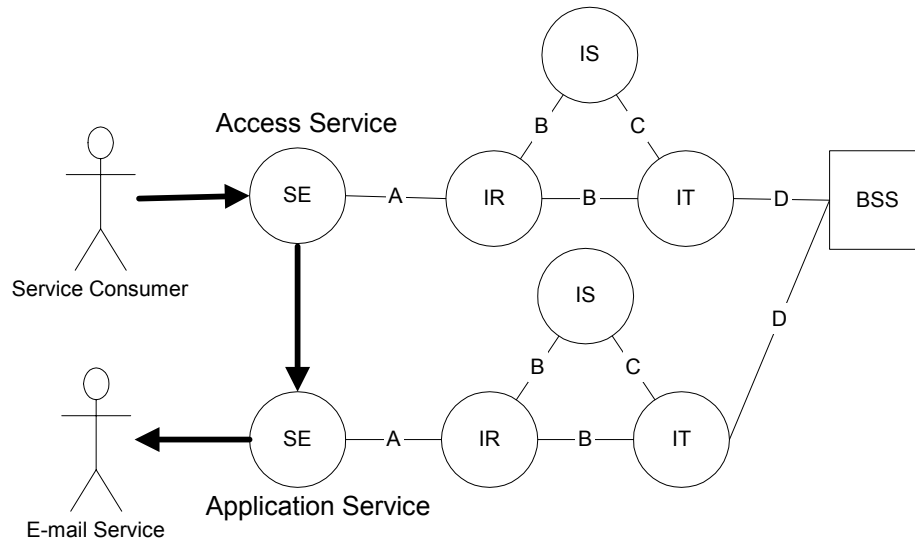

Figure 11:

If an ISP wants to unbundle its own local IP services to its subscribers it may offer several application services on its own local network. Each of these services along with the basic access service would be treated as separate SE nodes feeding into the common BSS system. As in Figure 10 both SEs feed into a common IR node, which then make shared usage of the IS node and the IT node. Figure 11 illustrates where completely separate IR, IS, and IT node sets serve each SE but all the IPDR usage records are still transmitted to a common BSS system. IRs are capable of receiving IPDRs from multiple SEs.

2.5.6 Separate Home, Access, Transport, and Application Service Providers Acting in Concert

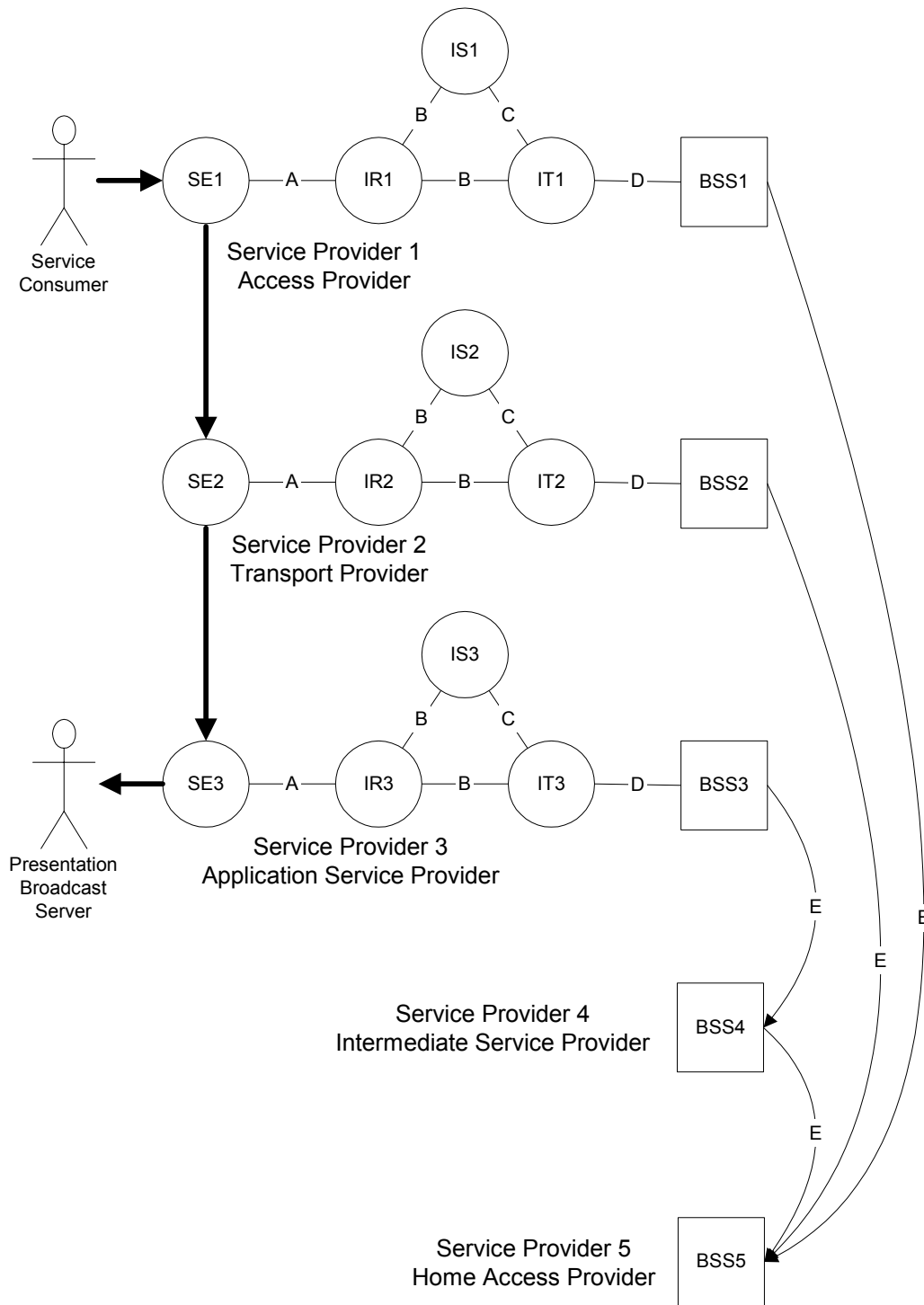

Figure 12: Separate Home, Access, Transport, and Application Service Providers Acting in Concert

This scenario illustrates how IP service providers can jointly provide a realistic application to a service consumer. The service consumer (SC) is:

1. Roaming outside of his home wireless service area
2. Using a digital cellular network interface (e.g. GPRS or CDMA2000) on a laptop computer
3. To participate in net meeting, using an internet connection to
4. View a broadcast Power Point presentation and
5. Call into a conference call bridge using VoIP;
6. The conference bridge is served by a PSTN, so the VoIP call is an IP-to-PSTN call, served by a gateway.

Figure 112 illustrates the interconnections among the service providers, while Figure 13 shows the sequence of IPDR message interactions between them. Five service providers participate in this scenario:

1. Access Service Provider (SP1) - this provider grants roaming access to the service consumer.
2. Transport Service Provider (SP2) - this provider interconnects service providers SP1 and SP3.
3. Application Service Provider (SP3) - this provider offers the application service, relying on one or more access/transport service providers to establish the session connection with service consumer.
4. Intermediate Service Provider (SP4) - this provider acts as an intermediate BSS on behalf of one or more other service providers. Such applications as service bureaus, clearing houses, rating bureaus, fraud bureaus, pre-paid authorization centers and other intermediate IPDR processing applications are examples of the role of this service provider.
5. Home Access Service Provider (SP5) – this is the service consumer’s home account service provider, which ultimately bills the consumer. The other service providers deliver settlement IPDRs to SP5.

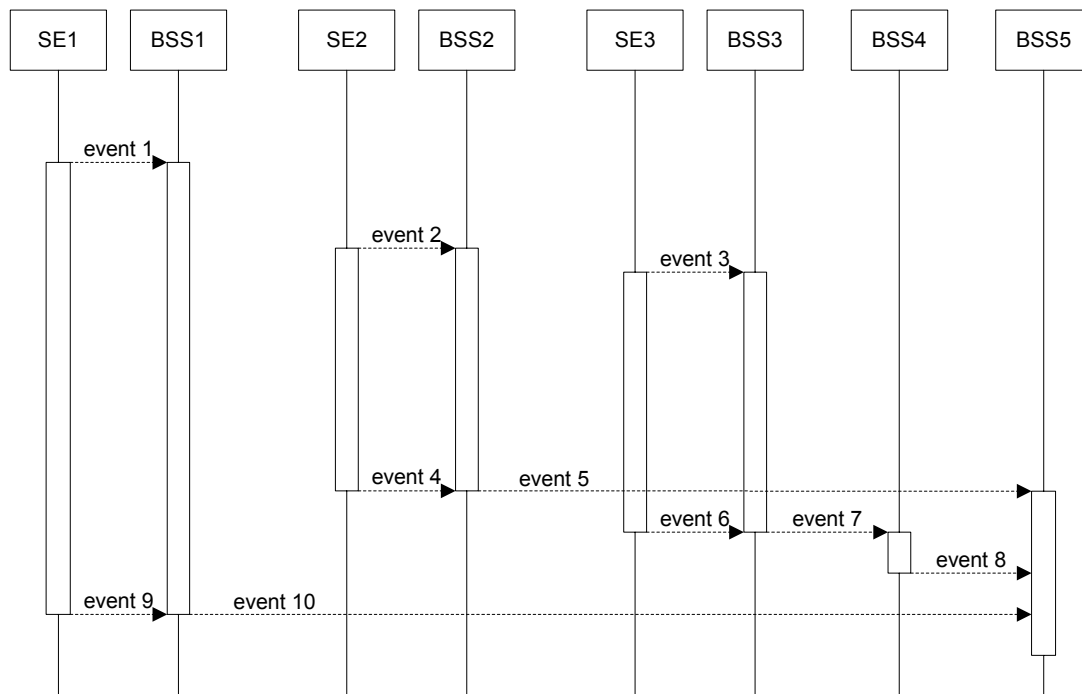

Figure 13

The following IPDR sequences of events occur:

1. SC initiates access request to the SP1. SE1 send start IPDR to BSS1
2. SC initiates VoIP call to Conference Bridge via SP2's gateway server,]. SE2 send start IPDR to BSS2.
3. SC initiates connection to SP3's presentation broadcast server. SE3 send start IPDR to BSS3
4. SC terminates VoIP call. SE2 send stop IPDR to BSS2
5. BSS2 send settlement IPDR to BSS5
6. SC terminates presentation session. SE3 send stop IPDR to BSS3.
7. BSS3 sends settlement IPDR to BSS4
8. BSS4 relays settlement IPDR to BSS5
9. SC terminates access. SE1 send stop IPDR to BSS1
10. BSS1 sends settlement IPDR to BSS5

To simplify this scenario the intervening IPDR messages passing to and from the IR, IS, and IT have been omitted in Figure 13. These IPDR messages have previously been discussed.

2.5.7 Content Delivery Use Case

The following Use Case provides the business problem context for which S/PS is a generic solution. It should be noted that, while the emphasis of this specification is on inter-enterprise use case scenarios, the specification could be equally applied to intra-enterprise scenarios where that makes good business sense for the enterprise in question.

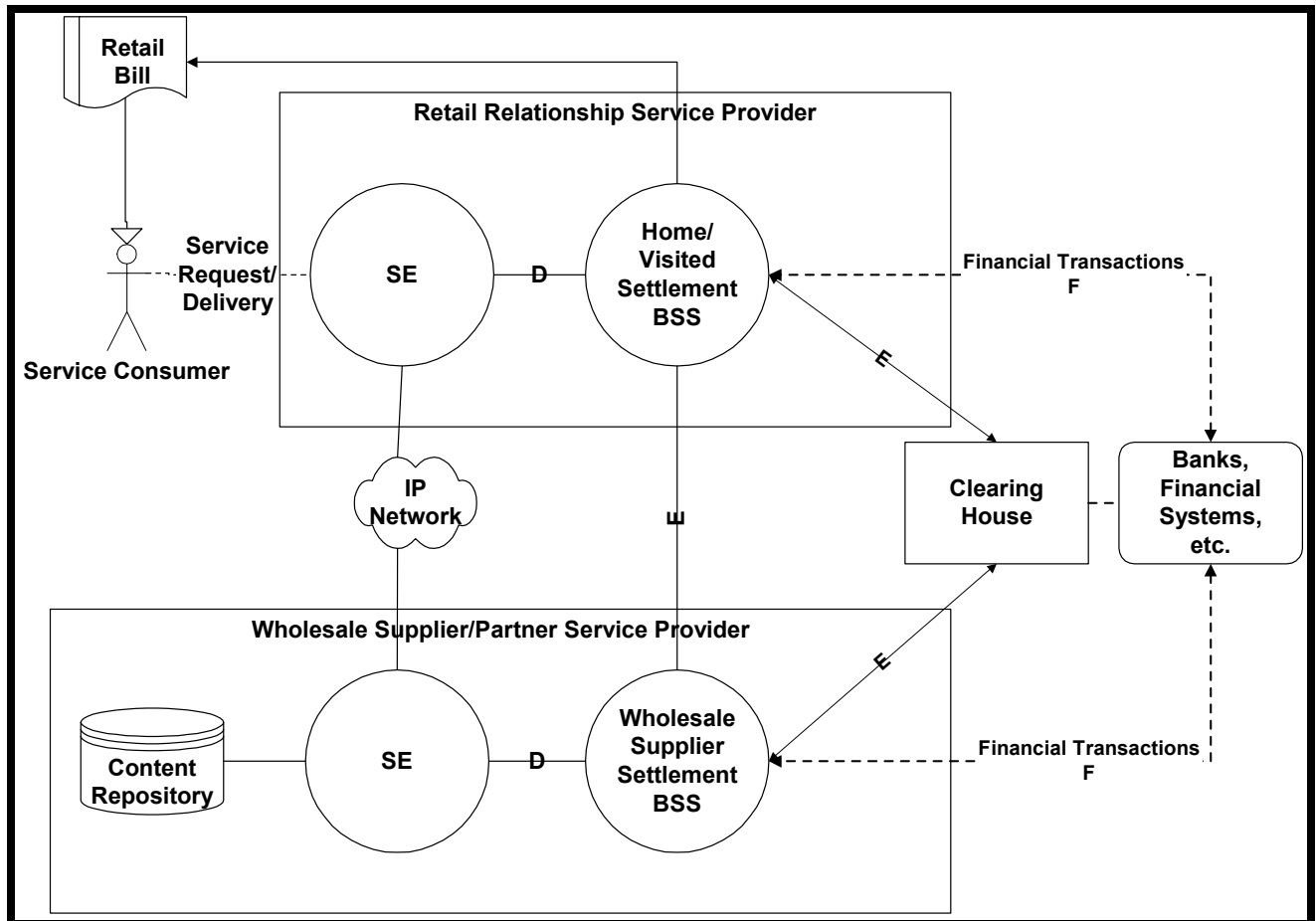

Figure 14- Use Case Diagram

The business case under analysis is that of a Service Consumer that has a retail customer relationship to a Retail Service Provider offering IP-based services. That Retail Service Provider has a wholesale business relationship with a Wholesale Service Provider which offers content delivery services. This Wholesale Service Provider elects to have the Retail Service Provider offer their content delivery services to the Service Consumer and leave to the Retail Service Provider the responsibility for collection of the fees for delivery of the content. When the Retail Service Provider collects the fees from the Service Consumer, they share the proceeds with the Wholesale Service Provider under a prearranged commercial agreement. Since the Retail Service Provider is assumed to have many such wholesale relationships, as does the Wholesale Service Provider, they both elect to engage the services of a Settlement company. Rather than send invoices and payments directly from each Supplier/Partner to each other, all the service providers send all of their transactions to the Settlement System and the transactions are

segregated by Supplier/Partner relationship. At a predetermined interval, the Settlement System calculates the amount due to/from each party and sends banking and financial transactions to the appropriate institutions and enterprises to effect the transfer of funds and to notify all parties as to the results.

The systems view of this business case is as follows:

1. The Service Consumer lodges a request for content delivery from the Service Element in the Retail Service Provider's domain.
2. The Retail Service Provider relays the request to the appropriate Service Element in the Wholesale Service Provider's domain.
3. The Wholesale Service Provider delivers the content as requested.
4. The Retail SE creates one or more IPDRs on the D interface to its appropriate BSS.
5. The Wholesale SE creates one or more IPDRs on the D interface to its appropriate BSS.
6. The Retail Service Provider's BSS sends/receives one or more transactions on its E interface with the Settlement System.
7. The Wholesale Service Provider's BSS sends/receives one or more transactions on its E interface with the Settlement System.

The purpose of the S/PS Specification is to identify the requirements for the "E" interfaces in this use case so that the Protocol Working Group can design a technical solution to meet the requirements. None of the other interfaces or interactions on the diagram is the direct subject of the S/PS and would be declared out of scope of the specification, including the "F" interface, which is the one on which financial transactions (e.g., EDI, bank transfers, etc.) would flow to consummate the settlement transactions.

2.5.8 Specific Usage Scenario – WiFi Roaming

The following is a specific application of the general use case discussed in the previous section. The service usage depicted is 802.11-family “WiFi” wireless internet access. The user is a retail customer of a Wireless Service Provider (WISP), denoted as WISP B. The Service Consumer (SC) is “roaming” in that they request internet access in a “hot spot” operated by WISP A. The figures below depict the major system components involved in this scenario for three variant scenarios.

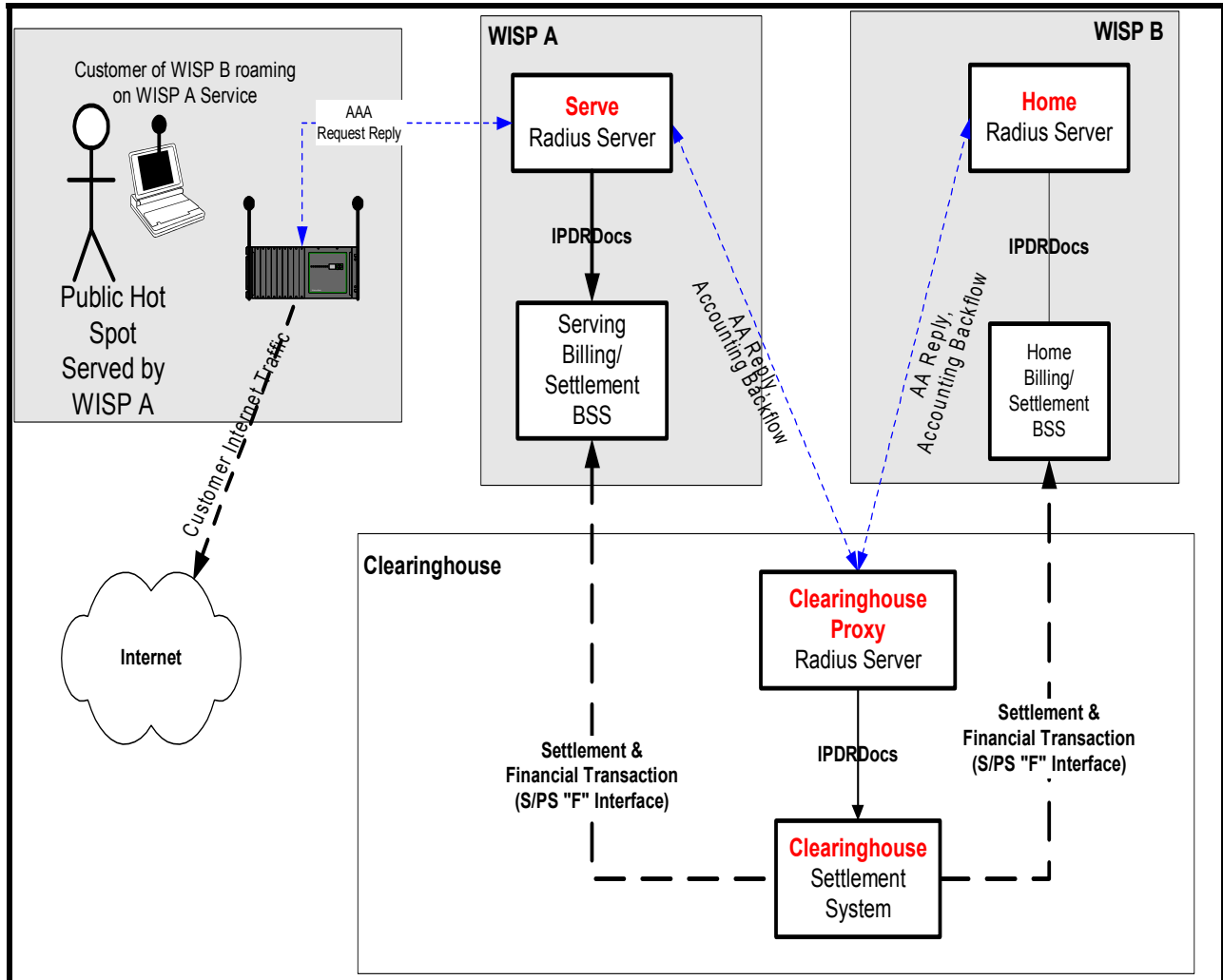

Figure 15 - WiFi Roaming Scenario 1: Clearinghouse with Radius Proxying

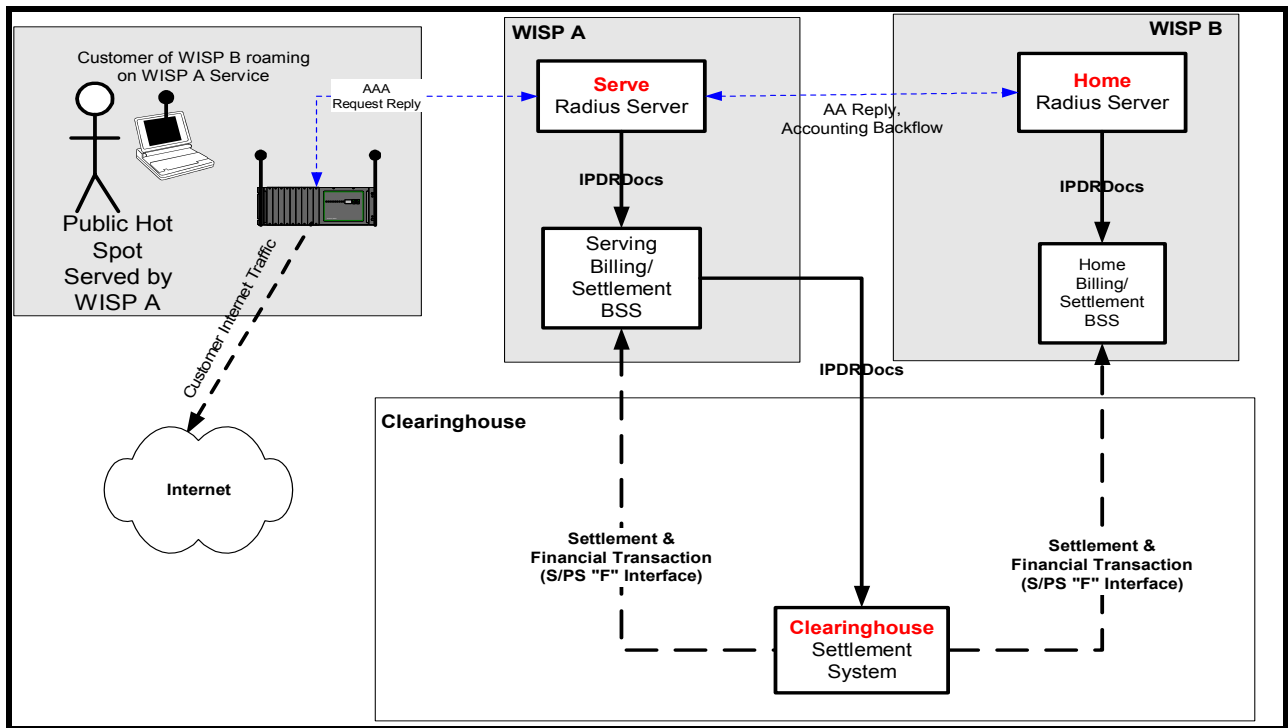

Figure 16 - WiFi Roaming Scenario 2: Clearinghouse and Direct Radius Connection

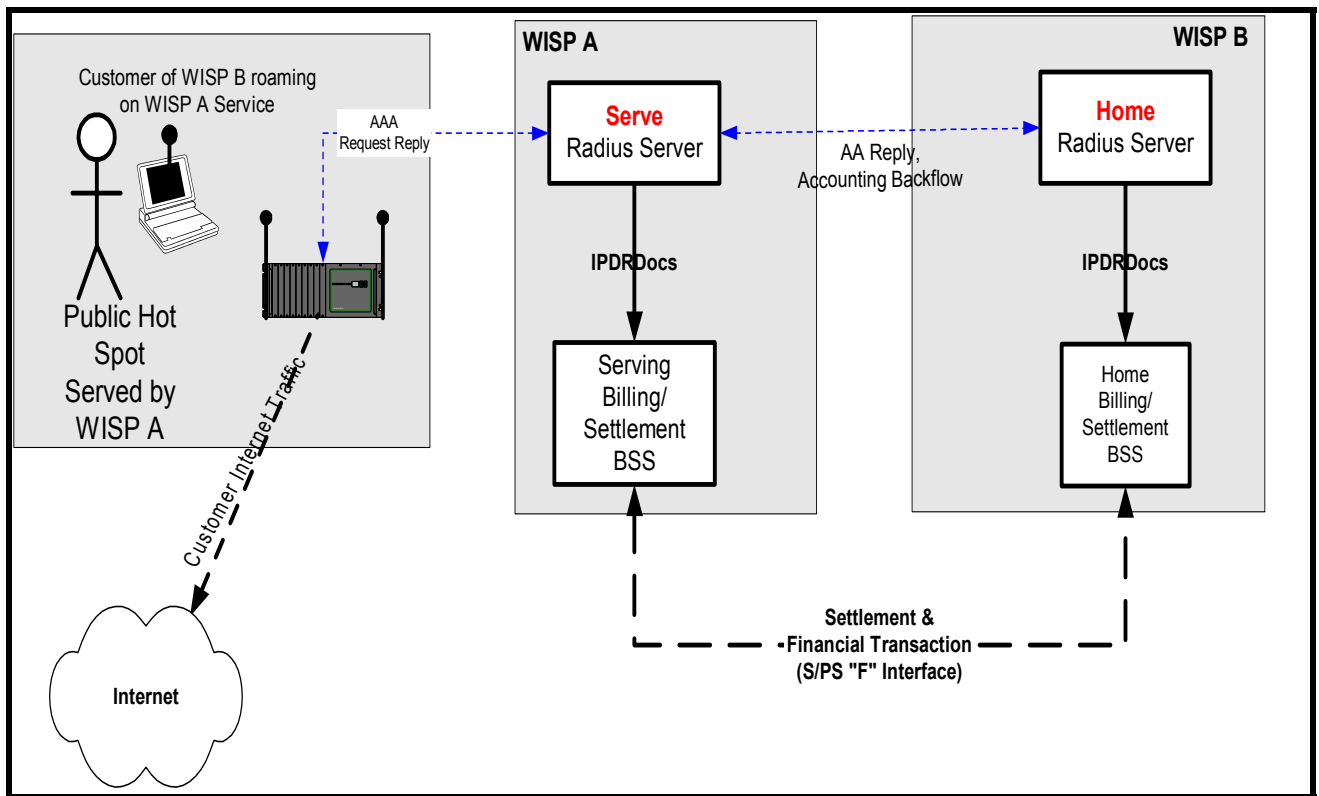

Figure 17 - WiFi Roaming Scenario 3: Bilateral Relationship

The following sequence of transactions comprises those applicable to this discussion:

1. Consumer/subscriber of wireless carrier B roams onto WLAN hotspot owned by WLAN provider A.
2. Consumer logs on at hotspot and is identified as a visitor from WISP B, with which WISP A has a roaming agreement.
3. WISP A (Serve) Radius queries WISP B (Home) Radius to do Authentication, Authorization, etc of subscriber. Once done, session is established.
4. Radius messages are proxied back and forth between Serve and Home during session, the content of which reflects the service capabilities offered to the roaming Service Consumer under the roaming agreement.
5. Consumer/Subscriber logs off and session is terminated.
6. Accumulated Radius detail is gathered from the Serve for this session, and IPDR record for settlement is created for the session and sent for settlement.
7. Settlement system reconciles data and provides appropriate information for transferring of funds between partners.

3. Requirements

3.1 Introduction

This chapter provides high-level requirements for BSS applications needs. It also provides the framework for specifying new IP services not already covered in the various standalone Service Specification documents.

Section 3.3 provides the general overview of the network model from previous chapters and its applicability to the BSS applications needs. The focus for specifying requirements is given to D interface though there may be implied requirements to other interfaces. Section 3.3 provides general requirements and general usage attributes applicable to any IP service. Note that any new IP service added in the future may impact the general requirements and usage attributes. Section 3.4 provides IP services covered and yet to be covered in this chapter.

The following sections detail the business requirements imposed on the design of information models and protocols to realize the S/PS application. Various requirements call out constraints on data format, protocol, and systems, respectively.

This document, as it relates to these definition of terms to describe the requirements of the S/PS specification, follows the conventions as outlined in [RFC2119]:

The key words “MUST”, “MUST NOT”, “REQUIRED”, “SHALL”, “SHALL NOT”, “SHOULD”, “SHOULD NOT”, “RECOMMENDED”, “MAY”, and “OPTIONAL” contained in this document are to be interpreted in the following manner:

REQUIRED – This word, or the terms “MUST” or “SHALL”, mean the definition is an absolute requirement to follow the S/PS recommendations.

MUST NOT – This phrase, or the phrase “SHALL NOT”, means the definition is an absolute prohibition to follow the S/PS recommendations.

RECOMMENDED – This word, or the adjective “SHOULD”, means there may exist valid reasons in particular circumstances to ignore a particular item, but the full implications must be understood and carefully weighed before choosing a different course.

NOT RECOMMENDED – This phrased, or the phrase “SHOULD NOT” means there may exist the valid reasons in particular circumstances when the particular behavior is acceptable or even useful, but the full implications should be understood and the case carefully weighed before implementing any behavior described with this label.

OPTIONAL – This word, or the adjective “MAY”, means that an implementer may choose to include the item because a particular business objective requires it or because they feel that it enhances the service while other implementers may choose to omit the item. An implementation, which does not include a particular option, **MUST** be prepared to interoperate with another

implementation that does include the option though with perhaps reduced functionality, and vice-versa.

3.2 Assumptions

1. Home Service Provider handles all business needs (via BSS applications) of the Service Consumer.
2. Service Consumer may or may not be within the Home Service Provider's service area.
3. BSS to BSS interfaces (E Interface) is outside the scope of this version of the specification.
4. Some applications of IPDR will result in large numbers of IPDRs being generated, requiring economical storage, transport, and processing implementations. Several requirements stated below are intended to address this assumption. However, no quantitative requirements regarding performance (end-to-end delay, transfer rate, etc.) or efficiency (message size, compression ratio, etc.) will be stated in this document. The mechanisms designed in later chapters of this document, which satisfy the general requirements in this area, should give implementers adequate tools to make cost versus technology tradeoffs, justified in light of the business problem being solved. Product vendors designing implementations of this specification are assumed to be aware of the overall marketplace requirements for such systems and service providers selecting one or more of these implementations will be expected to require those vendors to demonstrate competitive features in the area of performance.
5. A Settlement System is a BSS that meets the requirements for facilitating financial payments between partners based on business-to-business (B2B) bilateral agreements.
6. This specification focuses on the wholesale information exchanged between business enterprises only.
7. Other BSSs, interfacing with Settlement BSSs, have the responsibility of filtering any SP-private data and/or adding any settlement specific data prior to sending to the IPDRs.
8. Authentication of third parties in real-time and authorization of use of products and services requested is NOT in scope of this specification.
9. The technology of IPDR shall be used to the greatest extent practical to implement these requirements, thus minimizing the need for new development prior to the deployment of S/PS solutions.

3.3 Detailed Requirements

3.3.1 Mediation

The general requirements for mediation (defined here as all those functions performed between the A and D interfaces) are, in almost all cases, service independent. Depending on the business model mediation tasks could span a wide variety of actions. However, in general terms mediation tasks include the collection, generation, aggregation and reconciliation of IPDRs across Service Elements, geographical areas and time.

1. Mediation shall support both polling and the producer can initiate pushing for data transfer, so that the data transfer either by the consumer or autonomously.
2. Mediation shall support data transfer for both individual events and batches of events.
3. Mediation shall support retrieval of IPDR documents.
4. Service elements shall be uniquely identified within the scope of each terminating IPDR Recorder.
5. Each IPDR shall have a unique event identifier within service elements. If IPDRs are related and the relation is visible to the IPDR Recorder (aggregator) then, a reference to the related record (base IPDR) shall contain this unique identifier.
6. IPDR shall enable the interim recording across multiple service elements and time. That is, enabling event information to exist in multiple records, over several IPDR documents.
7. Mediation shall support uniquely identifying IPDR documents for the purpose of gap and duplicate detection.

3.3.2 BSS

1. The BSS shall support both pulling and pushing for data transfer, so that the data transfer either by the consumer or autonomously.
2. The BSS shall support data transfer for both transaction-oriented (near real time) events and batches of events.
3. The BSS shall support retrieval of IPDR documents.
4. Service elements shall be uniquely identified within the scope of each terminating Service Provider.
5. Each IPDR shall have a unique event identifier within Service Provider.
6. The BSS shall support uniquely identifying IPDR documents for the purpose of gap and duplicate detection.

3.3.3 Format

1. The IPDR format shall be extensible permitting the addition of any set of services and service specific usage attributes.
2. The IPDR format shall be able to self-describe its usage attributes.
3. The IPDR format shall capture sufficient information to identify an IPDR Service Consumer.
4. The IPDR format shall provide specified data types, so that various systems can interpret the data properly.
5. Times in IPDR should be expressed per ISO 8601 format for the purpose of facilitating data exchange.

6. The specific time precision requirements vary with applications (e.g., IP packet time as opposed to billing time) and are individually specified in the attribute list.
7. For billing purpose, time stamp accuracy should be 1 second or better.
8. Local time zone offset with reference to GMT should be provided and should reflect local time of calling party for correct billing.
9. The IPDR format shall support efficient encoding.
10. The S/PS format shall be extensible permitting the addition of any set of services and service specific usage attributes.
11. The S/PS format shall be able to self-describe its usage attributes.
12. The S/PS format shall capture sufficient information to identify an S/PS Service Consumer and Service Provider.
13. The S/PS format shall provide specified data types, so that various systems can interpret the data properly. Times in S/PS should be expressed per ISO 8601 format for the purpose of facilitating data exchange. The specific time precision requirements vary with applications (e.g., IP packet time as opposed to billing time) and are individually specified in the attribute list. For billing purpose, time stamp accuracy should be 1 second or better. Local time zone offset with reference to GMT should be provided and should reflect local time of calling party for correct billing.
14. The S/PS format shall support efficient encoding.
15. S/PS settlement data shall be contained in S/PS documents.

3.3.4 Application Protocol

1. The IPDR protocol shall support encryption of IPDR documents.
2. The IPDR shall use open protocols and description languages.
3. IPDR protocol/format shall separate the record format and exchange protocol.
4. IPDR protocol shall support transfer capabilities negotiation.
5. IPDR protocol shall support both individual and batch transfers of data.
6. IPDR protocol shall support resynchronization to a particular point in the order of delivery of IPDR documents.
7. The S/PS protocol shall support encryption of S/PS documents.
8. The S/PS protocol shall use open protocols and description languages.
9. The S/PS protocol/format shall separate the record format and exchange protocol.
10. The S/PS protocol should support transfer capabilities negotiation.
11. The S/PS protocol shall support both individual and batch transfers of data.
12. The S/PS protocol shall support resynchronization to a particular point in the order of delivery of S/PS documents.
13. The S/PS protocol shall support business process flow specification.

The business process flow specifications should be capable of negotiation between systems on a dynamic basis.

3.3.5 Usage Attributes

1. The IPDR format specification shall indicate, for all usage attributes, if the information is required, optional or conditional.
2. The IPDR format specification shall indicate usage attributes data type.
3. Where appropriate, a data type of value/unit shall be specified to denote the unit of measure of an associated attribute value.

4. The S/PS format specification shall indicate, for all usage attributes, if the information is required, optional or conditional.
5. The S/PS format specification shall indicate usage attributes data type.
6. Where appropriate, a data type of value/unit shall be specified to denote the unit of measure of an associated attribute value.

3.3.6 Settlement

1. The S/PS format shall support roaming.
2. The S/PS format shall support mobile service consumer.
3. The S/PS protocol shall allow secure communications.
4. The BSS shall interface with other BSSs via E-Interface.
5. The BSS interfacing via E interface shall have mechanism of acknowledgement for the S/PS documents sent/received.

3.3.7 IPDR Common Data Elements – Application “Envelope”

The IPDR application “envelope” shall contain:

1. The identity of each SP involved in the transport of IPDRDocs.
2. Any applicable retail and/or wholesale charges.
3. The type of service for which accounting is being recorded.
4. An indication of whether the usage is detailed or aggregated.

3.4 Listing of Services

3.4.1 Services Covered

For describing the context environment of the business requirements listed in this chapter, a set of services is analyzed. Then, for each service multiple use cases, stated from the perspective of the Service Consumer, are depicted. See the IPDR Service Specification library for the specifications of the services analyzed to date.

3.4.2 Services Considered by other Organizations

It is recognized that the specification of services requires expertise and experience in the providing or equipping such services. IPDR.org encourages domain experts and service providers to submit specifications of services whose usage would be recorded by an IPDR Recorder. The form of such submissions should conform to the templates and guidelines described in the Service Specification Design Guidelines.

3.5 Quality of Service (QoS) Metric Guidelines

Every service considered in Service Specification documents should contain metrics for Quality of Service (QoS).

3.5.1 QoS Metrics – General

Quality of Service (QoS) metrics characterize the quality level of a certain aspect of a service being offered, and ultimately the customer satisfaction. They represent the subjective and abstract “quality” as perceived by the user in terms of quantified values. QoS metrics can be used by service providers to manage and improve their service offering, as well as by the customers (end users or partner providers) to ensure that they are getting the level of quality that they are paying for. QoS metrics have now been used to support commercial applications such as SLA (service level agreement) formulation and verification. They are also used in call-minute trading, where price is determined by volume and quality grade. The IPDR service specifications have incorporated relevant QoS metrics to support such needs.

Telecom standards organizations, such as ITU-T study groups and QSDG (Quality of Service Development Group), have been working on extensive studies and recommendations on quality-assessment methodologies and metrics for the voice-band services (voice, fax, and modem) over PSTN. Their objective is to produce QoS metrics that are meaningful, validated to be accurate, and standardized for industry-wide use. These standards are now being enhanced, and new metrics being developed, to meet the needs of the emerging converged networks that use new technologies (e.g., IP, wireless), and offer new types of services (e.g., steaming media, web browsing, e-mails).

3.5.2 Categories of Quality of Service and Network Performance Metrics

QoS metrics can be primary parameters that are determined by direct measurement of call characteristics or events, such as circuit noise, echo path loss, or signaling release cause. Alternatively, QoS metrics can be derived from a collection of primary parameters – for instance,

- Statistical calculation (e.g., call completion rate for calls to a given destination for a day),
- Opinion modeling (e.g., Call Clarity Index estimated based on measured circuit parameters during a call), or
- Decision thresholds.

ITU-T (Rec. I.350) distinguishes conceptually between Quality of Service (QoS) and Network Performance (NP) metrics. QoS metrics pertain to end-user perceived, service-oriented attributes, while NP metrics pertain to network-provider focused, connection-oriented attributes (e.g., protocol parameters). QoS and NP metrics can be used to serve different objectives. For example, NP is useful for supporting wholesale SLA between two service providers, and QoS is useful for SLA applications involving end users.

ITU-T categorizes generic QoS parameters in terms of three functions (Access, User information transfer, and Disengagement) and the three performance criterion (Speed, Accuracy, and Dependency). Under this generic framework, specific QoS metrics can be defined to serve different applications and service types, such as:

- QoS metrics for different signal types, e.g., voice, fax, video.
- QoS metrics for one signal type (voice), but different service types, e.g., telephony conversational voice, streaming audio, voice-mail.
- QoS metrics for the same signal type and service type, but different classes of commercial offering, e.g., premium-price high-quality telephone voice service, as opposed to toll-free best-effort telephone service with advertisements.

3.5.3 Survey of Standardized QoS Metrics

This section provides a survey of existing standardized QoS metrics.

Call/Session Setup Success

This metric relates to the question “How successful am I in reaching the called party or the requested session?” For each call/session setup attempt, the completion code attribute in the IPDR represents the success/failure status of the setup attempt and indicates the reason for a failure. Meaningful statistical metrics can be derived over collections of calls – for instance, calls to a given destination per hour using a given carrier. ITU-T recommendations E.425 and E.600 provide definitions of the commonly used ASR (Answer-to-Seizure Ratio, the ratio of number of answered calls to number of seizures), and NER (Network Effectiveness Ratio). A similar statistical metric can be used to characterize the session-setup success rate for the generic IP-based services.

Call/Session Setup Delay

This metric relates to the question “How long is the waiting time to get to the called party or the session after the initial setup request?” For PSTN, this is represented by the commonly used PDD (Post Dialing Delay = time between the last dialed digit and the beginning of ring-back), or newer PGAD (Post Gateway Answer Delay) as defined in ITU-T Rec.E.431 and E.437. Target values for call setup delay have also been specified by ITU for local, toll and international connections (Rec. E. 721). For the new IP-based networks, generic “session setup delay” can be similarly defined.

Conversation and Voice Quality

This metric relates to the question “After I succeed in making a voice connection, how satisfactory is the conversation quality or voice quality during the call?” Conversation or voice quality can be affected by parameters such as noise, echo, speaking volume, transmission delay, and impairments due to voice compression, packet loss, and jitter. In particular, two-way interactive conversation quality is critically affected by transmission delays. There are a number of standards that relate to conversation or voice quality.

Subjective Evaluation

The most direct way to assess voice quality is evaluation by human subjects. ITU-T Recs. P.800 and P.831 provide specifications for a 5-point Mean Opinion Score (MOS) for voice quality assessment (1 = bad, 2 = poor, 3 = fair, 4 = good, 5 = excellent). Because subjective evaluation is costly and time-consuming in practical terms, objective evaluation techniques have been developed to estimate user-perceived MOS by means of psycho-acoustic models, which can be signal-based or parameter-based.

Call Clarity Index

ITU-T Rec. P.561 defines In-service Non-intrusive Measurement Devices (INMDs) for measuring voice-grade parameters (e.g., speech level, noise, and echo loss and delay) from live calls. ITU-T Rec. P. 562 describes the Call Clarity Index (CCI), a conversation opinion model that transforms per-call IMND parameters into a pair of MOS indices (1 to 5) to characterize the interactive conversation quality as perceived by the two participants in the call.

Transmission Rating R-factor

ITU-T Rec. G.107, “The E-model, a Computational Model for Use in Transmission Planning,” generates a transmission rating R-factor (0 to 100) that is based on input parameters pertaining to voice signal-to-noise ratio, impairment due to loudness and quantization, impairment due to echo and delay, and impairment due to equipment processing, as well as a customer-expectation factor.

User-Perceived R-factor

An alternative user-perceived R-factor can be derived from additional information pertaining to the occurrence characteristics of IP network impairments (e.g., packet loss). ETSI TS-101-329-5 V1.1.1 (2000-11), Annex-E, provides descriptions of such techniques.

Perceptual Evaluation of Speech Quality (PESQ)

ITU-T Rec. P.862 provides a standardized signal-based psycho-acoustic model (PESQ) for assessing speech listening quality (MOS) by comparing the received degraded signal against the transmitted reference signal, taking into account of different impairment effects that can be present in the emerging networks. New non-intrusive models also being evaluated in ITU can measure voice quality by comparing the live speech signals against known human speech characteristics, without using a transmitted reference signal.

Fax Transmission Quality

Fax transmission quality is important for business applications, especially in an international environment. Fax transmission QoS parameters are defined in ITU-T E.4xx recommendations. For example, Rec. E.458 specifies a figure of merit of fax transmission based on fax completion, maximum speed, and image errors. Rec. E.459 specifies fax transmission performance metrics using non-intrusive techniques. Rec. E.460 specifies fax performance metrics for V.34 Group 3 fax.

Network Performance Parameters

ITU-T Recommendation Y.1540 defines network parameters that may be used in specifying and assessing IP network performance. They are applicable to network segments or end-to-end connections. The defined parameter set includes the commonly used parameters of IPTD (IP Packet Transfer Delay), IPDV (IP Packet Delay Variation, or jitter), IPLR (IP Packet Loss Ratio), and IPER (IP Packet Error Ratio). In conjunction with the accompanying Rec. Y.1541, which provides target values for different QoS classes, these network performance parameters are useful for supporting SLA management at the wholesale level as well as at the end-user level.

Video Transmission Quality

The ITU-T VQEG (Video Quality Experts Group) and ITU-T SG9 are focused on video-quality issues. Rec. N.64 defines five-grade scales (1, 2, 3, 4, 5) that can be quality-based (bad, poor, fair, good, excellent) or impairment-based (Very annoying, Annoying, Slightly annoying, Perceptible but not annoying, Imperceptible). These scales can be used for subjective

assessment of video quality. Objective video-quality measurement techniques have also been addressed in Rec. J.143/J.144.

3.5.4 QoS Classes and Performance Objectives

Classes of QoS have been defined to facilitate QoS management for service and business applications. For example, QoS classes can be selected for different service types, or the same service type but different price brackets. Performance targets can be specified for each QoS class in terms of the value ranges of pertinent QoS metrics. The following are examples of QoS class definitions provided by standards organizations.

VoIP QoS Classes

ETSI TIPHON TS 101329-2, “Definition of Speech Quality QoS Classes,” provides guidelines for narrowband VoIP QoS classes (4 = high, 3 = medium, 2 = acceptable, and 1 = best-effort/no-guaranty) in terms of transmission rating R-factor, speech quality (equivalents of known voice-codec quality) and end-to-end delay. A new QoS class has been recently added for the wideband voice service.

Guidance for IP QoS Classes

ITU-T Rec. Y.1541, “Network Performance Objectives for IP-based Services,” defines six IP QoS classes (0 to 5) from the network perspective, on the basis of:

- Applications (from “real-time, jitter-sensitive, highly interactive” to “traditional application of default IP networks”)
- Node mechanism (from “separate queue with preferential servicing, traffic grooming” to “long queue, drop priority”), and
- Network techniques (from “constrained routing & distance” to “any route/path”).

For each QoS class, IP network-performance objectives are defined in terms of value ranges (upper bound) of measured IP network parameters: IPTD, IPDV, IPLR, and IPER. Because this guidance is specified from the network perspective, it is particularly useful for SLA support at the wholesale level (between service providers), where end-users’ perception may not be directly measurable.

End-user Multimedia QoS Categories

A new ITU-T recommendation (Rec. G.1010) specifies different multimedia QoS categories from the end-user’s perspective. Performance considerations are addressed in terms of three parameters (delay, delay variation, and information loss) for different service applications, including:

Audio: Conversational voice, voice messaging, high-quality streaming audio

Video: Videophone, one-way video

Data: Web-browsing (HTML), bulk data transfer/retrieval, transaction (e-commerce, ATM), command/control, still image, interactive games, Telnet, e-mail (server access), e-mail (server-to-server transfer), fax (“real-time”), fax (store & forward), data–low-priority transactions, data–Usenet

4. IPDR Information Metamodel

A single Master IPDR Schema Document declares elements common to all IP-based Services. A service-specific schema document is then used to define the usage attributes which describe usage events for a particular type of service. For example, an IPDR instance document that corresponds to Streaming Media services must account for the Movie Names, however an IPDR instance document corresponding to email services would not. For this reason Streaming Media and email services require separate service-specific schema documents.

The IPDR Document hierarchy allows an IPDRDoc to contain many usage records (IPDRs). Details about the consumer, service elements, and usage attributes are contained within each IPDR element. The master schema does not define any child elements for the IPDR element because these details are specific to a particular service and in fact may be different for each service.

Figure 18 graphically presents the different IPDR elements and their relationship to each other.

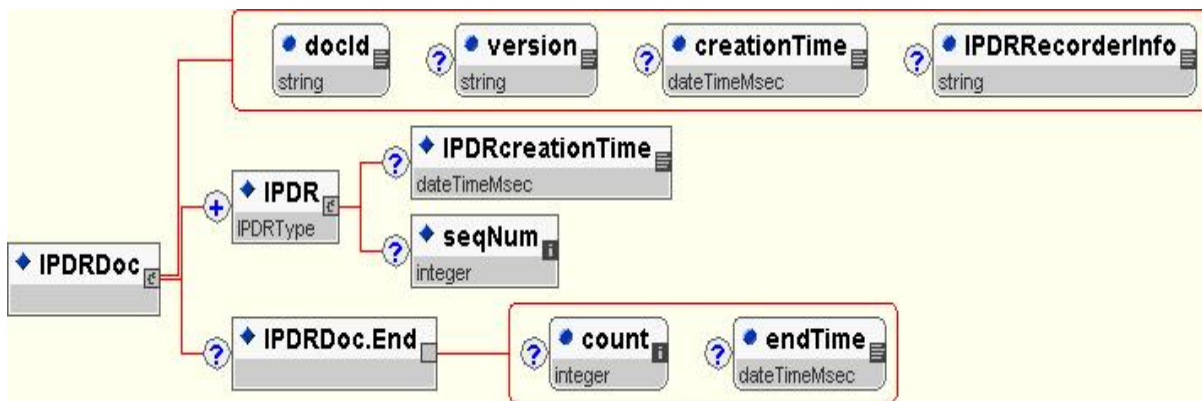

Figure 18

The document's main body is made up of one or more IPDRs that represent single usage events.

The document has an optional ending block of information represented by IPDRDoc.End.

An IPDR contains data describing the consumer, service provider, and metrics or parameters of a specific usage event. The usage represented may be measured as a discrete event, or part of an ongoing session.

Service specific schemas extend the base IPDR Schema by defining elements that are needed to characterize a usage event for that particular service.

4.1 IPDR Master Schema

The Master IPDR Schema Document formally describes how all IPDR documents are constructed. Additional details describing element use are included and considered part of the overall IPDR Document specification. Comments do not form part of the specification.

The Master IPDR Schema document is used as the basis for construction of Service specific schemas. Appendix A in this document provides detailed guidelines around the creation of service specific schemas and instance documents.

The most recent version of the Master IPDR Schema Document is available at:

<http://www.ipdr.org/public/IPDRDoc3.5.1.xsd>

The entire Master Schema is presented below and is followed by an annotated section containing further description and restrictions on the various elements. The annotations are considered part of the specification. The service-specific schema and annotations for the actual service specifications for the services listed in Chapter 3 follow in References [7] through [13].

```

<?xml version = "1.0" encoding = "UTF-8"?>
<!--Generated by Turbo XML 2.4.1.100. Conforms to w3c
http://www.w3.org/2001/XMLSchema-->
<!--Modified by SAC - 12/12/2004-->
<schema xmlns = "http://www.w3.org/2001/XMLSchema"
  targetNamespace = "http://www.ipdr.org/namespaces/ipdr"
  xmlns:ipdr = "http://www.ipdr.org/namespaces/ipdr"
  version = "3.5.1">
  <include schemaLocation = "http://www.ipdr.org/public/IPDRTypes.xsd"/>
  <element name = "IPDRDoc.End">
    <annotation>
      <documentation>
        The IPDRDoc.End element optionally marks the end of
the IPDR block. It may contain some check information like a count of IPDRs.
      </documentation>
    </annotation>
    <complexType>
      <attribute name = "count" type = "integer"/>
      <attribute name = "endTime" type = "ipdr:dateTimeMsec"/>
    </complexType>
  </element>
  <element name = "IPDRCreationTime" type = "ipdr:dateTimeMsec"/>
  <element name = "seqNum" type = "integer"/>
  <complexType name = "IPDRType">
    final = "restriction">
      <annotation>
        <documentation>
          This is the base type for the IPDR element. The
service-specific schema can extend this by deriving from it.
        </documentation>
      </annotation>
      <sequence>
        <element ref = "ipdr:IPDRCreationTime" minOccurs = "0"/>
        <element ref = "ipdr:seqNum" minOccurs = "0"/>
      </sequence>
    </complexType>
  <element name = "IPDR" type = "ipdr:IPDRType">
    <annotation>
      <documentation>
        An IPDR describes an event between a service consumer
and a service element. Details of the event are contained within this record.
All IPDR elements have a time indicating when the event
occurred.
      </documentation>
    </annotation>
  </element>
  <element name = "IPDRDoc">
    <annotation>
      <documentation>
        The IPDRDoc element is the top-level container of a
set of IPDRs. The document will also define the entity which recorded these
IPDRs via the IPDR element.
      </documentation>
    </annotation>
    <complexType>
      <sequence>
        <element ref = "ipdr:IPDR" maxOccurs = "unbounded"/>

```

```
        <element ref = "ipdr:IPDRDoc.End" minOccurs = "0"/>
      </sequence>
      <attribute name = "docId" use = "required" type =
"ipdr:UUID"/>
      <attribute name = "version" type = "string"/>
      <attribute name = "creationTime" type =
"ipdr:dateTimeMsec"/>
      <attribute name = "IPDRRecorderInfo" type = "string"/>
    </complexType>
  </element>
</schema>
```

4.2 Annotated IPDR Master Schema

A description of each element in the IPDR Schema Document is presented below.

IPDRDoc

```
<element name = "IPDRDoc">
  <annotation>
    <documentation>
      The IPDRDoc element is the top-level container of a set of
      IPDRs. The document will also define the entity which
      recorded these IPDRs via the IPDRRec element.
    </documentation>
  </annotation>
  <complexType>
    <sequence>
      <element ref = "ipdr:IPDR" maxOccurs = unbounded"/>
      <element ref = "ipdr:IPDRDoc.End" minOccurs = "0"/>
    </sequence>
    <attribute name = "docId" use = "required" type = "string"/>
    <attribute name = "version" type = "string"/>
    <attribute name = "creationTime" type =
"ipdr:dateTimeMsec"/>
    <attribute name = "IPDRRecorderInfo" type = "string"/>
  </complexType>
</element>
```

The attributes of the IPDRDoc element are described below.

- docId – A Universally Unique Identifier (UUID)
- version - identifies the version of the Master IPDRDoc Schema being used. This version shall be '3.1'.
- creationTime - indicates the time this document was created. (See the “Generic Requirements” section for more information about timestamps”)
- IPDRRecorderInfo – identity of the IPDR Recorder responsible for the creation of this IPDRDoc.

IPDRDoc.End

```
<element name="IPDRDoc.End">
  <complexType content="empty">
    <annotation>
      <documentation> The IPDRDoc.End element optionally marks the
      end of the IPDR block. It may contain some check
      information like a count of IPDRs.
    </documentation>
    </annotation>
    <attribute name="count" type="integer" use="optional"/>
    <attribute name="endTime" type="dateTimeMsec" use="optional"/>
  </complexType>
</element>
```

The attributes of the IPDRDoc.End element are described below.

- count - the number of IPDRs contained in this document (used as a check)..

- `endTime` - the time this document was completed. (See the “Generic Requirements” section for more information about timestamps”)

IPDR

```
<element name = "IPDR" type = "ipdr:IPDRType">
  <annotation>
    <documentation>
      An IPDR describes an event between a service consumer
      and a service element. Details of the event are contained
      within this record. All IPDR elements have a time
      indicating when the event occurred.
    </documentation>
  </annotation>
</element>
<element name = "IPDRCreationTime" type = "ipdr:dateTimeMsec"/>
<element name = "seqNum" type = "integer"/>
<complexType name = "IPDRType"
  final = "restriction">
  <annotation>
    <documentation>
      This is the base type for the IPDR element. The
      service-specific schema can extend this by deriving
      from it.
    </documentation>
  </annotation>
  <sequence>
    <element ref = "IPDRCreationTime" minOccurs = "0"/>
    <element ref = "seqNum" minOccurs = "0"/>
  </sequence>
</complexType>
```

The default child elements of the IPDR element are described below.

- `IPDRCreationTime` - the time the recorded usage event occurred. (See the “Generic Requirements” section for more information about timestamps”)
- `seqNum` - an optional integer value for auditing sets of IPDRs. The first IPDR in each IPDRDoc has a `seqNum` value of 0. Each subsequent IPDR within the same IPDRDoc has a monotonically increasing `seqNum`.

IPDRtypes

The following schema is lexically included in the IPDRDoc schema to provide the default types required to be used in service definition schemas:

```
<?xml version = "1.0" encoding = "UTF-8"?>
<!--Generated by Turbo XML 2.4.1.100. Conforms to w3c
http://www.w3.org/2001/XMLSchema-->
<xsd:schema xmlns:xsd = "http://www.w3.org/2001/XMLSchema"
  version = "3.5.1">
  <xsd:simpleType name = "dateTimeMsec">
    <xsd:annotation>
      <xsd:documentation>
        This type supports time resolution at the millisecond level It is further
        constrained to always use the timezone designator "Z" indicating GMT.
      </xsd:documentation>
    </xsd:annotation>
  </xsd:simpleType>
</xsd:schema>
```

Quantities of this type can optionally use 3 digits of fraction after the second to represent the milliseconds. If absent, it is assumed the millisecond component is ".000".

Example: 1999-05-31T13:20:00.561Z

```

        </xsd:documentation>
    </xsd:annotation>
    <xsd:restriction base = "xsd:string">
        <xsd:pattern value = "[0-9]{4}\-[0-9]{2}\-[0-9]{2}T[0-9]{2}:[0-9]{2}:[0-9]{2}(\.[0-9]{3})?Z"/>
    </xsd:restriction>
</xsd:simpleType>
<xsd:simpleType name = "dateTimeUsec">
    <xsd:annotation>
        <xsd:documentation>
            This type supports time resolution at the microsecond level. It is further constrained to always use the timezone designator "Z" indicating GMT. Quantities of this type can optionally use 6 digits of fraction after the second to represent the microseconds. If absent, it is assumed the microsecond component is ".000000". Example: 1999-05-31T13:20:00.561843Z
        </xsd:documentation>
    </xsd:annotation>
    <xsd:restriction base = "xsd:string">
        <xsd:pattern value = "[0-9]{4}\-[0-9]{2}\-[0-9]{2}T[0-9]{2}:[0-9]{2}:[0-9]{2}(\.[0-9]{6})?Z"/>
    </xsd:restriction>
</xsd:simpleType>
<xsd:simpleType name = "ipV4Addr">
    <xsd:annotation>
        <xsd:documentation>
            An IP version 4 address in dotted notation decimal. Example: 15.13.120.22
        </xsd:documentation>
    </xsd:annotation>
    <xsd:restriction base = "xsd:string">
        <xsd:pattern value = "[0-9]{1,3}\.[0-9]{1,3}\.[0-9]{1,3}\.[0-9]{1,3}" />
    </xsd:restriction>
</xsd:simpleType>
<xsd:simpleType name = "ipV6Addr">
    <xsd:annotation>
        <xsd:documentation>
            An IP version 6 address in colon separated 2 byte block hexadecimal notation.
            Example: FEDC:AB19:12FE:0234:98EF:1178:8891:CAFF
        </xsd:documentation>
    </xsd:annotation>
    <xsd:restriction base = "xsd:string">
        <xsd:pattern value = "[0-9a-fA-F]{4}:[0-9a-fA-F]{4}:[0-9a-fA-F]{4}:[0-9a-fA-F]{4}:[0-9a-fA-F]{4}:[0-9a-fA-F]{4}:[0-9a-fA-F]{4}:[0-9a-fA-F]{4}" />
    </xsd:restriction>
</xsd:simpleType>
<xsd:simpleType name = "UUID">

```

```
<xsd:annotation>
  <xsd:documentation>
    A universal unique id in hex dash notation.
    Example: f81d4fae-7dec-11d0-a765-00a0c91e6bf6

  </xsd:documentation>
</xsd:annotation>
<xsd:restriction base = "xsd:string">
  <xsd:pattern value = "[0-9a-fA-F]{8}\-[0-9a-fA-F]{4}\-[0-9a-
fA-F]{4}\-[0-9a-fA-F]{4}\-[0-9a-fA-F]{12}"/>
</xsd:restriction>
</xsd:simpleType>
<xsd:simpleType name = "macAddress">
  <xsd:annotation>
    <xsd:documentation>
      A Medium Access Control address in hyphen separated 1
byte block hexadecimal notation.
      Example: 0F-2C-D0-44-2E-09
    </xsd:documentation>
  <xsd:appinfo>
    <reference>IEEE 802(R)-2001</reference>
  </xsd:appinfo>
</xsd:annotation>
  <xsd:restriction base = "xsd:string">
    <xsd:pattern value = "[0-9a-fA-F]{2}\-[0-9a-fA-F]{2}\-[0-9a-
fA-F]{2}\-[0-9a-fA-F]{2}\-[0-9a-fA-F]{2}\-[0-9a-fA-F]{2}"/>
  </xsd:restriction>
</xsd:simpleType>
</xsd:schema>
```